

Development Control B Committee Agenda



Date: Wednesday, 21 February 2024

Time: 6.00 pm

Venue: The Council Chamber - City Hall, College Green, Bristol, BS1 5TR

Members of the public attending meetings or taking part in Public Forum are advised that all Development Control meetings are filmed for live or subsequent broadcast via the council's webcasting pages. The whole of the meeting is filmed (except where there are confidential or exempt items) and the footage will be available for two years.

If you ask a question or make a representation, then you are likely to be filmed and will be deemed to have given your consent to this. If you do not wish to be filmed you need to make yourself known to the webcasting staff. However, the Openness of Local Government Bodies Regulations 2014 now means that persons attending meetings may take photographs, film and audio record the proceedings and report on the meeting (Oral commentary is not permitted during the meeting as it would be disruptive). Members of the public should therefore be aware that they may be filmed by others attending and that is not within the council's control.

Councillors: Ani Stafford-Townsend (Chair), Chris Windows (Vice-Chair), Lesley Alexander, Amal Ali, Fabian Breckels, Sarah Classick, Lorraine Francis, Katja Hornchen and Guy Poultney

Copies to: Norman Cornthwaite, Allison Taylor (Democratic Services Officer), Jeremy Livitt, Rachael Dando, David Fowler (Members' Office Manager (Conservative)), Stephen Fulham, Paul Shanks, Stephen Peacock (Chief Executive), Philippa Howson, John Smith (Executive Director: Growth & Regeneration), Jonathan Dymond, Simone Wilding, Jane Woodhouse and Lewis Cook

Issued by: Jeremy Livitt, Democratic Services
City Hall, PO Box 3399, Bristol, BS1 9NE

Tel: 
E-mail: democratic.services@bristol.gov.uk

Date: Tuesday, 13 February 2024

www.bristol.gov.uk

Agenda

1. Welcome, Introduction and Safety Information

2.00 pm

(Pages 5 - 8)

2. Apologies for Absence

3. Declarations of Interest

To note any interests relevant to the consideration of items on the agenda.

Any declarations of interest made at the meeting which are not on the register of interests should be notified to the Monitoring Officer for inclusion.

4. Minutes of the previous meeting

To agree the minutes of the last meeting as a correct record.

(Pages 9 - 13)

5. Action Sheet

There were none.

6. Appeals

To note appeals lodged, imminent public inquiries and appeals awaiting decision.

(Pages 14 - 24)



7. Enforcement

To note enforcement notices.

(Page 25)

8. Public forum

Any member of the public or councillor may participate in public forum. The detailed arrangements for so doing are set out in the Public Information Sheet at the back of this agenda. Please note that the following deadlines will apply in relation to this meeting:

Questions:

Written questions must be received three clear working days prior to the meeting. For this meeting, this means that your question(s) must be received at the latest by 5pm on **15 February 2024**.

Petitions and statements:

Petitions and statements must be received by noon on the working day prior to the meeting. For this meeting, this means that your submission must be received at the latest by 12.00 noon on **20 February 2024**.

The statement should be addressed to the Service Director, Legal Services, c/o The Democratic Services Team, City Hall, 3rd Floor Deanery Wing, College Green,
P O Box 3399, Bristol, BS1 9NE or email - democratic.services@bristol.gov.uk

PLEASE NOTE THAT IF YOU WISH TO SPEAK AT THE COMMITTEE, YOU ARE REQUESTED TO INDICATE THIS WHEN SUBMITTING YOUR STATEMENT OR PETITION. ALL REQUESTS TO SPEAK MUST BE ACCOMPANIED BY A WRITTEN STATEMENT.

In accordance with previous practice adopted for people wishing to speak at Development Control Committees, please note that you may only be allowed 1 minute subject to the number of requests received for the meeting.

If you have any further questions, please see the Development Control B Committee Public Forum FAQ for more information

<https://democracy.bristol.gov.uk/documents/s86621/Public%20Forum%20FAQ%20for%20Development%20Control%20Committees.pdf>

Members of the press and public who plan to attend a public meeting at City Hall are advised that you will be required to sign in when you arrive and you will be issued with a visitor pass which you will need to display at all times.



9. Planning and Development

To consider the following applications for Development Control Committee B - **(Page 26)**

- a) 1. 23.04315.LA - Statue of Edward Colston Colston Avenue (Pages 27 - 105)
- Final Committee Report**

10. Date of Next Meeting

2pm 10 April 2024



Public Information Sheet

Inspection of Papers - Local Government (Access to Information) Act 1985

You can find papers for all our meetings on our website at www.bristol.gov.uk.

Attendance at Public meetings

Public meetings including Cabinet, Full Council, regulatory meetings (where planning and licensing decisions are made) and scrutiny are held at City Hall.

Members of the press and public who plan to attend a public meeting at City Hall are advised that you will be **required to sign in** when you arrive and you will be issued with a visitor pass which you will **need to display at all times**.

Please be advised that you may be asked to watch the meeting on a screen in another room should the numbers attending exceed the maximum occupancy of the meeting venue.

COVID-19 Safety Measures

We request that no one attends a Council Meeting if they:

- are suffering from symptoms of COVID-19 or
- have tested positive for COVID-19

Other formats and languages and assistance for those with hearing impairment

You can get committee papers in other formats (e.g. large print, audio tape, braille etc) or in community languages by contacting the Democratic Services Officer. Please give as much notice as possible. We cannot guarantee re-formatting or translation of papers before the date of a particular meeting.

Committee rooms are fitted with induction loops to assist people with hearing impairment. If you require any assistance with this please speak to the Democratic Services Officer.

Public Forum

Members of the public may make a written statement ask a question or present a petition to most meetings. Your statement or question will be sent to the Committee Members and will be published on the Council's website before the meeting. Please send it to democratic.services@bristol.gov.uk.

The following requirements apply:



- The statement is received no later than **12.00 noon on the working day before the meeting** and is about a matter which is the responsibility of the committee concerned.
- The question is received no later than **5pm three clear working days before the meeting.**

Any statement submitted should be no longer than one side of A4 paper. If the statement is longer than this, then for reasons of cost, it may be that only the first sheet will be copied and made available at the meeting. For copyright reasons, we are unable to reproduce or publish newspaper or magazine articles that may be attached to statements.

By participating in public forum business, we will assume that you have consented to your name and the details of your submission being recorded and circulated to the Committee and published within the minutes. Your statement or question will also be made available to the public via publication on the Council's website and may be provided upon request in response to Freedom of Information Act requests in the future.

We will try to remove personal and identifiable information. However, because of time constraints we cannot guarantee this, and you may therefore wish to consider if your statement contains information that you would prefer not to be in the public domain. Other committee papers may be placed on the council's website and information within them may be searchable on the internet.

During the meeting:

- Public Forum is normally one of the first items on the agenda, although statements and petitions that relate to specific items on the agenda may be taken just before the item concerned.
- There will be no debate on statements or petitions.
- The Chair will call each submission in turn. When you are invited to speak, please make sure that your presentation focuses on the key issues that you would like Members to consider. This will have the greatest impact.
- Your time allocation may have to be strictly limited if there are a lot of submissions. **This may be as short as one minute.**
- If there are a large number of submissions on one matter a representative may be requested to speak on the groups behalf.
- If you do not attend or speak at the meeting at which your public forum submission is being taken your statement will be noted by Members.
- Under our security arrangements, please note that members of the public (and bags) may be searched. This may apply in the interests of helping to ensure a safe meeting environment for all attending.
- As part of the drive to reduce single-use plastics in council-owned buildings, please bring your own water bottle in order to fill up from the water dispenser.

For further information about procedure rules please refer to our Constitution

<https://www.bristol.gov.uk/how-council-decisions-are-made/constitution>



Webcasting/ Recording of meetings

Members of the public attending meetings or taking part in Public forum are advised that all Full Council and Cabinet meetings and some other committee meetings are now filmed for live or subsequent broadcast via the council's [webcasting pages](#). The whole of the meeting is filmed (except where there are confidential or exempt items). If you ask a question or make a representation, then you are likely to be filmed and will be deemed to have given your consent to this. If you do not wish to be filmed you need to make yourself known to the webcasting staff. However, the Openness of Local Government Bodies Regulations 2014 now means that persons attending meetings may take photographs, film and audio record the proceedings and report on the meeting (Oral commentary is not permitted during the meeting as it would be disruptive). Members of the public should therefore be aware that they may be filmed by others attending and that is not within the council's control.

The privacy notice for Democratic Services can be viewed at www.bristol.gov.uk/about-our-website/privacy-and-processing-notice-for-resource-services



Development Control Committee Debate and Decision Process

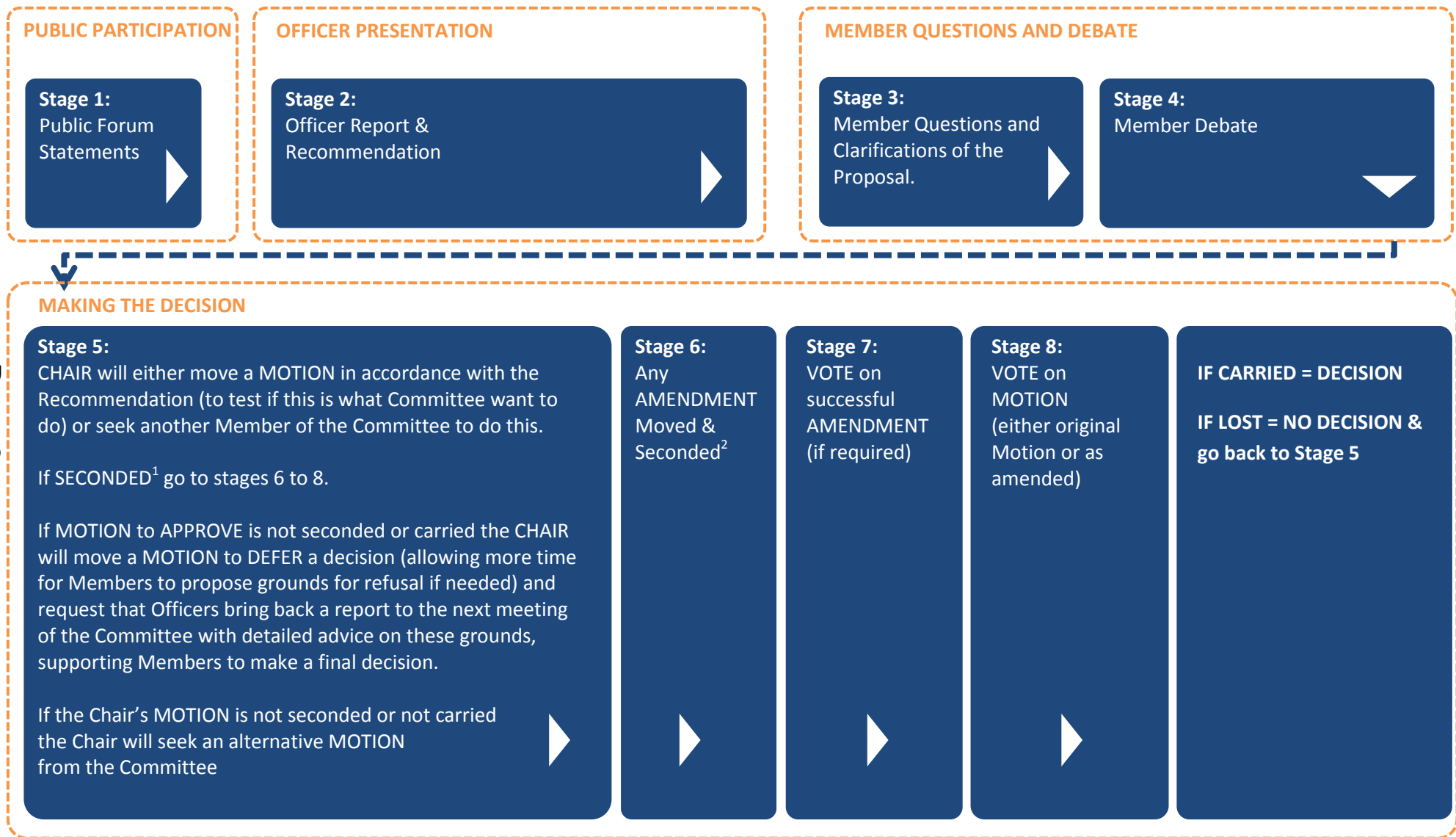

Page 8

¹ A Motion must be Seconded in order to be formally accepted. If a Motion is not Seconded, the debate continues

² An Amendment can occur on any formally approved Motion (ie. one that has been Seconded) prior to Voting. An Amendment must itself be Seconded to be valid and cannot have the effect of negating the original Motion. If Vote carried at Stage7, then this becomes the Motion which is voted on at Stage 8



Bristol City Council
Minutes of the Development Control B Committee

29 November 2023 at 6 pm



DRAFT

Members Present:

Councillor: Ani Stafford-Townsend (Chair), Lesley Alexander, Amal Ali, Sarah Classick, Lorraine Francis, Katja Hornchen, Farah Hussain (sub for Fabian Breckels), Guy Poultney

Officers in Attendance:

Steve Gregory, Philippa Howson, Simone Wilding, Lewis Cook

25 Welcome, Introduction and Safety Information

The Chair welcomed all parties to the meeting and drew attention to the emergency evacuation procedure in the event of an emergency.

26 Apologies for Absence

Apologies for absence were received from Councillor Fabian Breckels who was substituted by Councillor Farah Hussain. Noted that Councillor Chris Windows (Vice-Chair) was not present.

27 Declarations of Interest

Councillor Ani Stafford-Townsend declared that she had been lobbied by the applicant regarding this application.

28 Minutes of previous meetings

RESOLVED –

- a) That the minutes of the meeting held on 6 September 2023 be confirmed as a correct record subject to the last sentence on page 13 bullet point 8 being amended to read 'An Equalities Impact is a planning consideration that needs to be considered in all planning applications.'
- b) That the minutes of 18 October 2023 be confirmed as a correct record.

29 Action Sheet

There were no issues arising from the Action Sheet.



30 Appeals

Officers gave the following comments concerning appeals:

1. 91 - 101 Church Road Redfield Bristol - Appeal against non-determination had been dismissed.
2. Ever Ready House Narrowways Road Bristol - Appeal against non-determination had been postponed until February 2024.

31 Enforcement

There were no enforcement issues reported.

Members were assured that everything possible was being done to recruit more enforcement officers and despite the significant work pressures, there had been some improvement thanks to the hard work of the enforcement team.

32 Public Forum

Members of the Committee received Public Forum Statements and Questions & Answers in advance of the meeting. The public forum business had been published online prior to the meeting. All public forum was taken fully into consideration by the Committee prior to reaching a decision.

33 Planning and Development

The Committee considered the following Planning Application:

33a 22/05714/FB - South Bristol Crematorium and Cemetery, Bridgewater Road

Planning officers introduced the report and gave a detailed presentation to members of the committee.

The application was for full planning permission for the use of land designated as Green Belt for the expansion of the existing cemetery to provide new burial and memorial plots with associated roads, footpaths, parking, drainage infrastructure, fencing, landscaping and furniture. This included an extension of the cemetery into two currently undeveloped areas, and the provision of an attenuation pond in a further area.

The application was of significance to the city and had been subject to high levels of representation, both for and against the development. The application was previously reported to planning committee on 6th September 2023, with a recommendation for approval, however, following debate on the application the committee deferred a decision pending a further report being resubmitted to a future meeting which would have regard to possible reasons for refusal based on the issues suggested by members at the meeting.

The concerns raised were –

- a) Whether the strategic need for the cemetery was justified and what other areas had been explored.



- b) Whether there was a harmful impact on heritage assets.
- c) Whether the correct test had been applied in respect of the impacts on Biodiversity Net Gain and the SNCI, and whether late representations, including those from Avon Wildlife Trust had been fully addressed.
- d) Whether the impact on the viability of the neighbouring Yew Tree Farm had been properly assessed.

It was noted that the Applicant had since provided further evidence to justify the development, and address the concerns raised at the Committee meeting.

In response to the concerns raised officers were of the view that the previous recommendation was sound, subject to a revised suite of conditions. The updated report also provided further guidance on the issues raised by Members at the 6 September 2023 meeting.

Clarifications made following committee members questions:

1. Since the previous committee meeting the Publication Version of the revised Local Plan had been agreed by Full Council and was now available for public comment. It would therefore be a material consideration and have some limited weight in the decision-making process although it was emphasised that the current Local Plan would have overriding authority.
2. There were more ecology polices in the revised Local Plan and this continued the strong protection of sites of nature conservation interest in the future.
3. A Cemetery Strategy had not been subject to formal scrutiny as a formal strategy was not currently available. Regardless of this, members were reminded that the key function of the committee was to consider the Application before them on its own merits.
4. A new site for a cemetery was not considered to be realistically deliverable due to higher costs, greater land take and timescale issues. In addition, a new cemetery site would need to be subject to evaluation by the Law Commission. For these reasons the Application site was deemed to be the favoured option by Bristol City Council (BCC).
5. BCC had looked for other potential sites including other cemeteries but had found that they were already full to capacity. A Bristol site was preferred regarding the Council's climate policies, including reducing environmental impacts by reducing traffic movements in and out of the city. The Application was fully compliant with the Council's climate policies. The Committee was reminded that the consideration of alternatives was not necessary in planning terms and that the applicant had done everything they needed to do to satisfy planning requirements.
6. Biodiversity Net Gain as far as was known had not been settled in law by a case study. Notwithstanding this, members were reminded that the Application had to be considered as it stood and as a whole. It was explained that maintaining the specific characteristics for which the SNCI was designated and BNG were separate issues in law. The Application was fully compliant with SNCI policy and therefore did not require mitigation as the site would be managed and improved. The Council's ecologists had confirmed that the Application was in line with council policy.
7. Reference to loss of biodiversity in the November 2022 report would be counterbalanced by the overall site management plan. It was clarified that currently there was no legal requirement requiring 10% uplift for biodiversity, only an undefined amount of net gain was required to be policy compliant.
8. The Grade 2 listed Farmhouse did not require additional conditions to protect it as this would be regulated by the management plan which limited what could be put on graves. The regulations regarding this were strict and contained powers to remove objects if they were not compliant.
9. The onsite Management Strategy as submitted would ensure that conservation measures overall



would negate any potential, small-scale specific biodiversity loss.

10. Proposed hedgerow removal as part of the development would be limited to the encroaching scrub of lesser biodiversity value which is not part of the specific characteristics of the SNCI designation. In addition, there would be substantial planting of new hedgerows, the aim of which would be to increase the overall biodiversity of the site.
11. Ancient trees on the site would be fully protected as enforcement by tree officers was well resourced and it had been confirmed that enforcement would be well managed.
12. The estimated future capacity of burial plots on site due to ground conditions was debated, and Members were advised that this was difficult to predict. Members were informed that burial capacity was currently under review nationally which would inform future use of cemetery sites. There was no conflict with planning policy.
13. Regarding comments by the Avon Wildlife Trust about biodiversity net loss, members were reminded that protected species were subject to special legislation and the council's ecologists had reviewed the comments and concluded that the scheme would not impact on protected species on the site.

Committee Members debated the application and made the following comments:

14. No formal evidence had been provided about alternative sites and a lack of a formal cemetery strategy available for proper scrutiny meant approving the application could not be done in a balanced way. Members were forced to rely on an agreement of a bespoke management plan. If SNCI species had to be moved, it was unclear how this would work, this appeared to be heavily reliant on good will.
15. Not enough weight had been given to equalities impacts. People who cared about burial sites were not well represented at the meeting. It appeared that not all other potential options had been fully explored.
16. There had not been enough time to analyze the ecology report, more time was needed for an in-depth analysis on this.
17. There had been no obvious public support for the vaunted gain of biodiversity on this site, and no new protections had been applied. EIA impact derived from running out of cemetery space, and the site appeared to be selected as it was administratively and financially convenient and no other alternatives given and no apparent strategic case.
18. The Bristol area was the best site for practical reasons and there was a clear need for balance between cemeteries and conservation.
19. It was clear that more burial sites were needed, the only question being, was the site the only real option given its conflict with nature conservation. The Council had not made a strong case that this was the only site possible for future burial needs and there had not been a formal report detailing that the council was running out of burial spaces. More evidence was needed that wider research for alternative sites had been done to justify progressing the proposal in an SCNI.

In accordance with standard procedure Councillor Ani Stafford-Townsend moved the officer recommendation contained in the report to grant planning permission and this was seconded by Councillor Katja Hornchen.

On being put to the vote there were five in favour and three against.

RESOLVED - that the application be granted subject to conditions and delegations to officers.

35 Date of Next Meeting



The next meeting is scheduled for 2pm on Wednesday 10 January 2024 in the Council Chamber, City Hall, Bristol.

The meeting ended at 8.40 pm.

CHAIR _____



DEVELOPMENT CONTROL COMMITTEE B

21st February 2024

REPORT OF THE DIRECTOR: DEVELOPMENT OF PLACE

LIST OF CURRENT APPEALS

Householder appeal

Item	Ward	Address, description and appeal type	Date lodged
1	Westbury-on-Trym & Henleaze	137 Northover Road Bristol BS9 3LG Retention of existing metal railings to roof of single storey extension to rear of property and implementation of new timber screening to sides. Appeal against refusal Delegated decision	25/08/2023
2	Stoke Bishop	133 Shirehampton Road Sea Mills Bristol BS9 2EA First floor rear extension (over an existing ground floor extension). Appeal against refusal Delegated decision	19/12/2023
3	Windmill Hill	1 Somerset Terrace Bristol BS3 4LL Loft conversion with concealed roof terrace. Appeal against refusal Delegated decision	17/01/2024
4	Stoke Bishop	37 Glenavon Park Bristol BS9 1RW Proposed side infill single storey extension, front porch, roof replacement including raising the height and external alterations to fenestration (including velux windows), rear doors and dormer roof extensions (revision of consent granted 22/02387/H). Appeal against refusal Delegated decision	17/01/2024
5	Clifton	9 Church Lane Clifton Bristol BS8 4TX Removal of existing roof and installation of loft extension to create accommodation. Appeal against refusal Delegated decision	17/01/2024

6	Redland	7 Glentworth Road Redland Bristol BS6 7EG Alterations to the front garden area and boundary wall to accommodate one no. off street parking space (resubmission of application 21/06021/H). Appeal against refusal Delegated decision	19/01/2024
7	Redland	1 Egerton Road Bristol BS7 8HN Removal of existing rear lean-to and replacement with single storey full width rear extension. Proposed new mansard roof to replace existing hip roofs. Appeal against refusal Delegated decision	24/01/2024
8	Filwood	3 Kenmare Road Bristol BS4 1PD Double storey extension to side. Appeal against refusal Delegated decision	07/02/2024
9	Westbury-on-Trym & Henleaze	2 Broadway Avenue Bristol BS9 4SU Hip-to-gable loft conversion with rear dormer. Appeal against refusal Delegated decision	07/02/2024

Informal hearing

Item	Ward	Address, description and appeal type	Date of hearing
10	Lockleaze	Ever Ready House Narroways Road Bristol BS2 9XB Outline application with access, layout and scale to be considered, for demolition of existing buildings and redevelopment of site to provide up to 40no. C3 dwellings and up to 3no. Class E units with associated drainage and hard/soft landscape works. (MAJOR) Appeal against non-determination	27/02/2024

Written representation

Item	Ward	Address, description and appeal type	Date lodged
11	St George Troopers Hill	106 Fir Tree Lane Bristol BS5 8BJ Demolition of dwellinghouse and erection of a three-storey building comprising 9no. self-contained flats with associated soft and hard landscaping. Appeal against non-determination	22/06/2023

12	Avonmouth & Lawrence Weston	19 Capel Road Bristol BS11 0RD New dwelling. Appeal against refusal Delegated decision	26/09/2023
13	Horfield	2 Bishopthorpe Road Bristol BS10 5AA Change of use from a dwelling house (Use Class C3(a)) to a large HMO (house in multiple occupation) (sui generis) for up to 7 people. Appeal against non-determination Delegated decision	11/10/2023
14	Frome Vale	7 Hedgemoad Close Bristol BS16 1ER Appeal against High Hedge comprising cypress leylandii trees affecting 8 Stokecliffe House, 114 Park Road. Appeal against high hedge	23/10/2023
15	Hillfields	25 Dominion Road Bristol BS16 3EP Demolition of existing garage and erection of one semi detached dwelling on land to the side of existing house. Appeal against refusal Delegated decision	25/10/2023
16	Bedminster	9-11 Rear Of, Flat A Cannon Street Bedminster Bristol BS3 1BH Application for a Lawful Development Certificate for an Existing Use or Operation or Activity - Use of the rear building as 4 flats; Flat A, B, C and D. Appeal against non-determination	27/10/2023
17	Bedminster	9 South Liberty Lane Bristol BS3 2SR Roof extension and conversion of upper floors from commercial, business, and services (Use Class E) to self-contained maisonette (Use Class C3), with associated works. Appeal against non-determination Delegated decision	30/10/2023
18	Brislington East	15 Hollywood Road Bristol BS4 4LF Change of use from a dwellinghouse used by a single person or household (C3a) to a large dwellinghouse in multiple occupation (sui generis) for up to eight people. Appeal against non-determination Delegated decision	31/10/2023

19	Horfield	489 Gloucester Road Horfield Bristol BS7 8UG Outline application for demolition of the existing buildings (4no. Houses in Multiple Occupation - Class C4) - and 1no. flat (Class C3) and erection of new building comprising 9 residential apartments (Class C3) and 7 small Houses in Multiple Occupation (Class C4); associated cycle parking, waste storage, landscaping and other works (all matters reserved). Appeal against refusal Delegated decision	02/11/2023
20	Henbury & Brentry	Land To Rear Of 2 Arnall Drive Bristol BS10 7AP Proposed new dwelling including demolition of existing garage. Appeal against non-determination	06/11/2023
21	Southville	36 - 38 East Street Bedminster Bristol BS3 4HE Variation of condition 9 (approved plans) in connection with 22/04197/F for Subdivision of ground floor to provide 2 no. commercial units: first and second floor and roof extension to provide new residential accommodation. Appeal against non-determination	07/11/2023
22	Windmill Hill	21 Hill Avenue Bristol BS3 4SN Construction of a rear roof extension and fitting of rooflights to form a loft conversion. Appeal against non-determination	08/11/2023
23	Southville	52 Bedminster Parade Bristol BS3 4HS Part conversion of ground floor from A1 use to C3. Appeal against non-determination	13/11/2023
24	Southville	267 North Street Bedminster Bristol BS3 1JN Rear extension at second floor level and erection of new floor of residential; accommodation, refuse/recycling and cycle store and ancillary development. Appeal against non-determination	20/11/2023
25	Lockleaze	85 Hogarth Walk Bristol BS7 9XS Application for a Lawful Development Certificate for a Proposed Use or Development - A change of use from dwelling (C3) to small HMO (C4) is proposed. A 3 metre deep single-storey extension is proposed to the rear of the house. Appeal against non-determination Delegated decision	22/11/2023

26	Hengrove & Whitchurch Park	91 Walsh Avenue Bristol BS14 9SQ New dwelling attached to side of existing. Appeal against refusal Delegated decision	19/12/2023
27	Hartcliffe & Witherwood	1 Chaundey Grove Bristol BS13 9QY Erection of a two storey extension to existing property to create new 2 bedroomed dwelling. Appeal against refusal Delegated decision	19/12/2023
28	St George Central	361 Two Mile Hill Road Bristol BS15 1AF Application for a Certificate of Proposed Development - change of use of the rear area of the shop into a 1 bedroom flat. Appeal against non-determination	20/12/2023
29	Southville	Top Floor Flat 7 Acramans Road Bristol BS3 1DQ Loft extension. Appeal against refusal Delegated decision	02/01/2024
30	Southville	76 East Street Bedminster Bristol BS3 4EY Change of use of part of ground floor retail space, and first floor ancillary office space, to a small house in multiple occupation for up to 6 people (Use Class C4), including the erection of front and rear roof extensions to create second-floor accommodation. Alterations to shopfront to create new access. Appeal against non-determination	03/01/2024
31	Bedminster	South Bristol Retail Park Wedlock Way Bristol BS3 2LQ Variation of Conditions 14 (opening hours) and 15 (drive-thru serving hours) of permission 22/01002/F, which approved the erection of a new building with a drive-thru facility and associated works to site layout - now proposed change to hours to allow opening from 05:00 - 23:00, seven days per week. Appeal against refusal Delegated decision	11/01/2024
32	Eastville	59 Grove Park Terrace Bristol BS16 2BL Application for a Certificate of Proposed Development - Conversion of an existing detached garage into a home office and storeroom. Appeal against non-determination	15/01/2024

33	Central	39 - 40 High Street City Centre Bristol BS1 2AT Change of use from public house to nine bedroom boutique hotel. Erection of part fourth floor to create a further bedroom and outside space. Appeal against non-determination	15/01/2024
34	Hartcliffe & Witherwood	2A Vigor Road Bristol BS13 9QH Conversion of double garage into a 1 bed dwelling. Appeal against refusal Delegated decision	17/01/2024
35	Southville	2 Stillhouse Lane Bristol BS3 4EB Change of use from Commercial Workshop to 5no. Residential Apartments. Appeal against refusal Delegated decision	18/01/2024
36	Central	14 Highbury Villas Kingsdown Bristol BS2 8BX Application for a Lawful Development Certificate for an Existing Use as a 7 Bed sui generis HMO. Appeal against non-determination Delegated decision	22/01/2024
37	Horfield	7 Maskelyne Avenue Bristol BS10 5BY Change of use from small house in multiple occupation (C4) to a large house in multiple occupation (sui generis) with a loft conversion and provision of cycle parking and bin storage. Appeal against non-determination	25/01/2024
38	Hillfields	Land Adjoining Barton Hill Rugby Club Duncombe Lane Bristol BS15 1NS Application to determine if prior approval is required for the proposed installation of a 20 metre Swann Column monopole with 6 no. antennas and 4 no. dishes, together with 6no. cabinets, fencing and associated ancillary works. Appeal against refusal Delegated decision	29/01/2024
39	Brislington East	8 St Brelades Grove Bristol BS4 4QJ First floor rear extension. Appeal against non-determination	29/01/2024
40	Bishopsworth	33 Headley Lane Bristol BS13 7QL Remove out buildings and construct single storey rear and side extension. Appeal against non-determination Delegated decision	30/01/2024

41	Bishopston & Ashley Down	74 Oak Road Bristol BS7 8RZ Partial demolition of the existing building and the construction of a three storey building containing 6no. flats. Appeal against refusal Delegated decision	30/01/2024
42	Horfield	5 Bishopthorpe Road Bristol BS10 5AA Change of use from small house in multiple occupation (C4) to a large house in multiple occupation (sui generis) with a loft conversion and provision of off-street car parking, cycle parking and bin storage. Appeal against non-determination	05/02/2024

List of appeal decisions

Item	Ward	Address, description and appeal type	Decision and date decided
43	Hengrove & Whitchurch Park	Bamfield Streetworks Bamfield Bristol BS14 0XD Application to determine if prior approval is required for a proposed telecommunications installation: Proposed 15.0m Phase 8 Monopole C/W wrapround cabinet at base and associated ancillary works. Appeal against refusal Delegated decision	Appeal dismissed 06/10/2023
44	Ashley	6 Sussex Place Bristol BS2 9QW Conversion of this single dwelling into two flats and a maisonette, including provision of bin/cycle storage facilities and associated external alterations. Appeal against non-determination Delegated decision	Appeal allowed 11/12/2023 Costs awarded
45	Knowle	100 Redcatch Road Bristol BS4 2HQ Erection of dwelling (Renewal of planning permission granted on appeal ref APP/Z0116/W/18/3196399 - BCC 16/06418/F) - self build. Appeal against non-determination	Appeal allowed 26/01/2024
46	Knowle	100 Redcatch Road Bristol BS4 2HQ Demolition and re-building of curtilage listed stone wall with brick capping in the same position as the existing wall. Appeal against non-determination	Appeal allowed 26/01/2024

47	Ashley	6 Sussex Place Bristol BS2 9QW Conversion of this single dwelling into two flats and a maisonette including the renovation of the property as a listed building. Appeal against non-determination	Appeal allowed 11/12/2023 Costs awarded
48	Ashley	23 Wathen Road Bristol BS6 5BY Appeal against enforcement notice for works to roof without planning permission. Appeal against an enforcement notice	Appeal allowed 04/01/2024
49	Clifton Down	11 Wellington Park Bristol BS8 2UR Appeal against a High Hedge. Appeal against high hedge	Appeal dismissed 06/02/2024
50	Horfield	Beaufort Multi Storey Car Park Southmead Hospital Southmead Road Bristol BS10 5FN External alterations to the south-western and north-eastern elevations of the Car Park. Appeal against refusal Delegated decision	Appeal dismissed 19/12/2023
51	Bishopsworth	Highways Land Between Church Road And Whitchurch Road Bristol Application to determine if prior approval is required for a proposed: Streetpole style telecommunications mast. Appeal against refusal Delegated decision	Appeal dismissed 19/12/2023
52	Cotham	65 Lower Redland Road Bristol BS6 6SR Application for a lawful development certificate for an existing use as a large HMO (Sui-generis). Appeal against refusal Delegated decision	Appeal allowed 22/12/2023
53	Stockwood	88 Stockwood Road Stockwood Bristol BS14 8JE Demolition of single storey side conservatory and construction of 2-storey, 2-bed dwelling together with associated works, including rear extension. Appeal against refusal Delegated decision	Appeal dismissed 18/12/2023
54	Hengrove & Whitchurch Park	Land Adjacent To 16 Belland Drive & 24 Belland Drive Bristol BS14 0EW Erection of detached dwellinghouse. Appeal against refusal Delegated decision	Appeal dismissed 16/01/2024

55	Cotham	89 High Kingsdown Bristol BS2 8ER Enforcement notice appeal for change of use of property to small hmo use class C4. Appeal against an enforcement notice	Appeal allowed 03/01/2024
56	Brislington East	37 Hollywood Road Bristol BS4 4LD Demolition of an attached garage and the erection of a 1-bed, 2-person, attached dwelling with associated works. Appeal against refusal Delegated decision	Appeal dismissed 13/12/2023
57	Ashley	Flat 2 8 Argyle Road St Pauls Bristol BS2 8UU Retention of use as a small HMO (C4) for 3-6 people. Appeal against refusal Delegated decision	Appeal allowed 12/12/2023
58	Ashley	Flat 1 10 Argyle Road St Pauls Bristol BS2 8UU Retention of use as a small house in multiple occupation (C4) for 3-6 people. Appeal against refusal Delegated decision	Appeal allowed 12/12/2023
59	Ashley	Flat 1 8 Argyle Road St Pauls Bristol BS2 8UU Retention of use as a small house in multiple occupation (C4) for 3-6 people. Appeal against refusal Delegated decision	Appeal allowed 12/12/2023
60	Clifton	Ground Floor Flat 34 Royal Park Bristol BS8 3AN Proposed replacement of existing timber sliding sash with the 'ULTIMATE' sliding sash windows from the Roseview collection, to both front & rear. Appeal against refusal Delegated decision	Appeal dismissed 19/12/2023
61	Eastville	142 Fishponds Road Eastville Bristol BS5 6PT Two storey rear extension. Appeal against refusal Delegated decision	Appeal allowed 16/01/2024
62	Hillfields	274 Lodge Causeway Bristol BS16 3RD Change of use from dwelling C3 to 6 bedroom HMO C4. Appeal against refusal Delegated decision	Appeal dismissed 19/12/2023

63	Stoke Bishop	78 Shirehampton Road Stoke Bishop Bristol BS9 2DR Enforcement notice appeal for construction of enclosure to rear flat roof. Appeal against an enforcement notice	Appeal dismissed 05/01/2024
64	St George Troopers Hill	64 Dundridge Lane Bristol BS5 8SH Proposed two storey single dwelling house, with single storey rear extension and porch to the existing property. Appeal against refusal Delegated decision	Appeal allowed 09/01/2024
65	Clifton	Worlds End House Worlds End Lane Bristol BS8 4TH Works including repair/replacement of lean-to roof, doors and windows, construction of single storey rear extension. Repair/refurbishment and re-ordering of interior, and external landscaping. Appeal against non-determination	Appeal dismissed 07/02/2024
66	Clifton	Worlds End House Worlds End Lane Bristol BS8 4TH Works including repair/replacement of lean-to roof, doors and windows, construction of single storey rear extension. Repair/refurbishment and re-ordering of interior, and external landscaping. Appeal against non-determination	Appeal dismissed 07/02/2024
67	Ashley	12 Cairns Crescent Bristol BS2 9QD Domestic extension to a C3 dwelling. Double storey rear extension with roof extension loft conversion to create 7 bedroom dwelling. Appeal against non-determination	Appeal dismissed 18/12/2023
68	Bishopston & Ashley Down	229 - 231 Gloucester Road Bishopston Bristol BS7 8NR New building to provide 2 no. residential flats with refuse/recycling, cycle storage and associated development. Appeal against non-determination	Appeal dismissed 26/01/2024
69	Brislington West	59 Langton Road Bristol BS4 4ER Notification of Prior Approval for the erection of a single storey rear extension that would exceed beyond the rear wall of the original house by 5.4 metres, have a maximum height of 3 metres and have eaves that are 2.8 metres high. Appeal against non-determination	Appeal withdrawn 27/12/2023

70	Brislington West	Go Outdoors Tramway Road Brislington Bristol BS4 3DS 1no. Econoflex face sign - Internally illuminated, 1no. fabricated ACM panel - Non illuminated, 12no. flat ACM panels - Non illuminated and 1no. existing totem over clad with new ACM panels - Non illuminated. Appeal against refusal Delegated decision	Appeal allowed 02/02/2024
----	------------------	---	------------------------------

DEVELOPMENT CONTROL COMMITTEE B
21st February 2024

REPORT OF THE DIRECTOR: DEVELOPMENT OF PLACE

LIST OF ENFORCEMENT NOTICES SERVED

Item	Ward	Address, description and enforcement type	Date issued
1	Westbury-on-Trym & Henleaze	203 Wellington Hill West Bristol BS9 4QL Erection of structure to front. Enforcement notice	23/01/2024

Development Control Committee B 21 February 2024

Report of the Director: Economy of Place

Index

Planning Applications

Item	Ward	Officer Recommendation	Application No/Address/Description
1	Central	Grant	23/04315/LA - Statue Of Edward Colston Colston Avenue Bristol BS1 4UA Proposal to move the statue of Edward Colston from Colston Avenue to M Shed.

index
v5.0514

WARD: Central

SITE ADDRESS: Statue Of Edward Colston, Colston Avenue Bristol BS1 4UA

APPLICATION NO: 23/04315/LA Listed Building Consent (Alter/Extend)

DETERMINATION DEADLINE: 2 January 2024

Proposal to move the statue of Edward Colston from Colston Avenue to M Shed.

RECOMMENDATION: Grant subject to Condition(s)

APPLICANT: Bristol City Council
City Hall
College Green
Bristol
BS1 5TR

The following plan is for illustrative purposes only, and cannot be guaranteed to be up to date.

LOCATION PLAN:

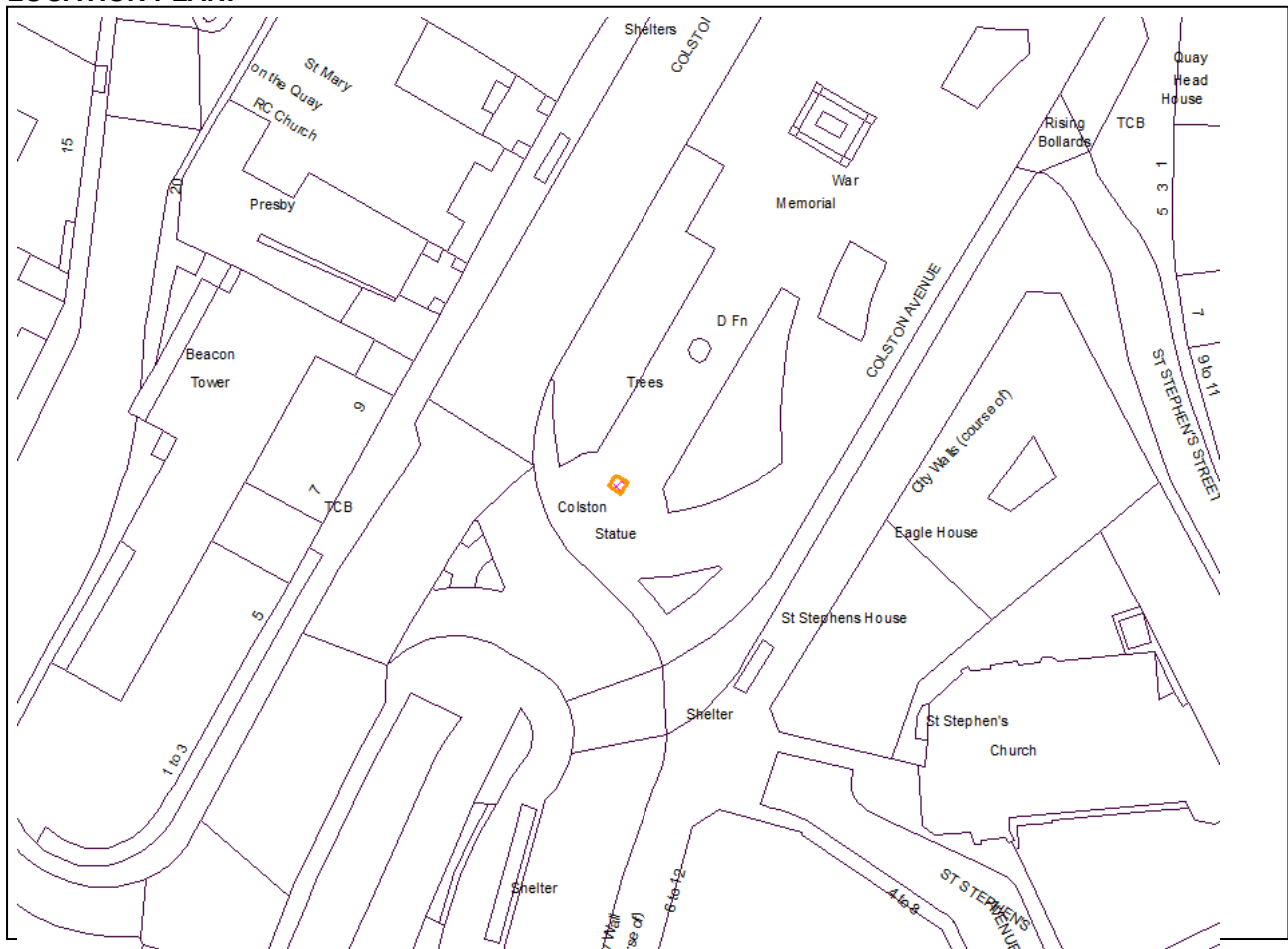

Development Control Committee B – 21 February 2024**Application No. 23/04315/LA : Statue Of Edward Colston Colston Avenue Bristol BS1 4UA****SUMMARY**

This is an application for Listed Building Consent to move the statue of Edward Colston from Colston Avenue to the M Shed. The application is made by Bristol City Council. The application has not been referred by a Ward Member to a DC Committee for a decision.

Listed Building Consent is required because the statue and plinth is Grade II listed. The plinth would remain in situ and a new plaque is also proposed.

The applicant has provided the following summary of events leading up to the submission of this application:

“On 7th June 2020, the grade II listed bronze statue of Edward Colston was pulled down from its plinth on Colston Avenue during a Black Lives Matter demonstration. After being rolled through the City Centre, the statue was dumped into the Floating Harbour by a crowd of demonstrators.

The statue was recovered from the harbour and in the summer of 2021 went on display in the museum. While on display, Bristol City Council and the History Commission that had been established by the authority following the events in June, ran a public consultation process with visitors to the exhibition and online. This consultation asked what people thought should now happen to the statue and surviving plinth in the City Centre. The results of this consultation process informed a report by the commission that concluded with 6 recommendations for the future of the statue and plinth.” This application seeks to implement a number of those recommendations.

This significance of the heritage asset has been identified and assessed. This is considered to be principally artistic and historic, with the historic significance of the statue and plinth having been increased following the events of June 2020.

It is concluded that the public benefits would outweigh the less than substantial harm posed. In reaching this conclusion, officers have given great weight to the heritage asset’s conservation, that is, the sustaining and enhancing of its significance. There is considered to be clear and convincing justification for the harm.

The proposal is therefore considered to be in accordance with the requirements of the NPPF, Bristol Core Strategy (2011) Policy BCS22 which seeks to ensure that development proposals safeguard or enhance heritage assets in the city, with Policy DM31 in the Site Allocations and Development Management Policies (2014) expressing that alterations to buildings should preserve or enhance historic settings.

Furthermore, this would be in accordance with Section 16 of the Planning (Listed Buildings and Conservation Areas) Act 1990 which states that in considering whether to grant listed building consent for any works the local planning authority shall have special regard to the desirability of preserving the building or its setting or any features of special architectural or historic interest which it possesses.

Special attention has also been paid to the desirability of preserving or enhancing the character or appearance of the Conservation Area in accordance with Section 72 of the Planning (Listed Buildings and Conservation Areas) Act 1990.

It is therefore recommended that Listed Building Consent be granted. Conditions are recommended regarding the implementation of the proposed works.

SITE AND SURROUNDINGS

The site is located in Bristol city centre in a prominent position on Colston Avenue. Colston Avenue is where many transport routes come together to form a very active and extensive area of public realm. The area is known as “The Centre”, an important civic and transport hub for the city.

The site is located within the College Green Conservation Area and close to the City and Queen Square Conservation Area. The Conservation Area has a Character Appraisal that was adopted in 2016 and the site falls within “The Centre” character area. The Character Appraisal refers to the Centre as “a major city landmark space and focal point for gathering, convening and events”. To emphasise the importance of the location, the city’s Cenotaph is located in relatively close proximity to the site.

The Conservation Area covers a large portion of the city centre, from the Council House and the Cathedral round to the areas of Colston Avenue that used to be part of the harbour until it was culverted in the late 19th Century. The linear area of public realm on Colston Avenue that contains the site, along with the varied and strong built form lining each side, reflect the quayside that was here, while the historic statues and features along the public realm reinforce elements of the City’s history.

In the College Green Conservation Area Character Appraisal the statue and plinth does not appear to be identified as a local landmark. There are other listed monuments nearby however.

The specific structure the subject of this application is the plinth that, until 7th June 2020, was the pedestal of the statue of Edward Colston that had been in situ since 1895. The statue and plinth were Grade II listed in March 1977.

The Official List Entry reads as follows:

“Heritage Category: Listed Building
Grade: II
List Entry Number: 1202137
Date first listed: 04-Mar-1977
List Entry Name: STATUE OF EDWARD COLSTON
Statutory Address 1: STATUE OF EDWARD COLSTON, COLSTON AVENUE

District: City of Bristol (Unitary Authority)
Parish: Non Civil Parish
National Grid Reference: ST 58628 73014

Details

BRISTOL

901-1/11/555 COLSTON AVENUE 04-MAR-77 CENTRE (Northeast side) STATUE OF EDWARD COLSTON

II This list entry has been amended as part of the Bicentenary commemorations of the 1807 Abolition Act.

Statue of Edward Colston, standing in Colston Avenue, to south of central pavement; the statue faces south. Erected 1895; the sculptor was John Cassidy of Manchester. A bronze statue on a pedestal of Portland stone. The statue shows Colston in middle age, dressed in C17 costume and leaning pensively on a stick. A rectangular moulded plinth with buttressed corners to a moulded pedestal; above this, consoles to an octagonal base supporting the statue. Inscribed on the south face of the base the words 'Edward Colston / Born 1636 / Died 1721'. To each corner of the pedestal, a bronze dolphin (dolphins feature on the Colston family crest), and on each face, a bronze plaque with Art Nouveau-style relief. On the south face, the words 'Erected by / citizens of Bristol / as a memorial / of one of the most / virtuous and wise sons of / their city / AD 1895' and 'John Cassidy fecit'. On the west face, Colston dispenses charity to poor children; on the north he is shown at the harbour; on the east is a scene with marine horses, mermaids, and anchors.

HISTORY: Edward Colston (1636-1721) was the son of a prosperous Bristol merchant; the family had long been established in Bristol. Edward Colston was apprenticed to the London Mercers' Company in 1654, in which he was enrolled in 1673. Thereafter, Colston established his own successful business in London, trading with Spain, Portugal, Italy, and Africa. The details of precisely how Colston's fortune was accumulated are not recorded, but his business interests were wide. Besides trading extensively in various commodities, including cloth and wine, he acted as a money-lender, and had interests in the West Indian island of St Kitts. In 1680 he became a shareholder in the Royal African Company. The Company, which had been founded in 1672 in place of the Royal Adventurers, had a monopoly on trade with Africa until 1688, after which time it received fees from English traders. Colston took a leading role in the Company, serving on several committees, and becoming deputy governor in 1689. Other members of the Colston family had connections with the Company; Edward's brother Thomas supplied beads that were used to buy slaves.

Although his trade was based in London, Colston continued to take an interest in his native Bristol; it is thought that he moved here for a while during the 1680s. He inherited a Bristol business from his brother, and became a partner in a Bristol sugar refinery, processing sugar produced by slaves in the West Indies. He was elected a free burgess of the city, and a member of the Society of Merchant Venturers, which meant that he could trade out of Bristol. By 1689 Colston had taken up residence at Mortlake, Surrey, where he lived for the rest of his life, but the philanthropic benefaction for which he was to become famous was concentrated on Bristol, the city for which he was MP from 1710-14.

Edward Colston is buried at All Saints' Church in Bristol, where a monument, designed by Gibbs and carved by Rysbrack, lists his charities. The bronze statue in Colston Avenue was commissioned by a committee organised by J. W. Arrowsmith, a Bristol printer and publisher and a promoter of the Exhibition, whose premises overlooked the site. The statue was unveiled by the Lord Mayor of Bristol on 13 November 1895.

Until the 1990s, Colston's involvement in the slave trade, the source of much of the money which he bestowed in Bristol, went largely unremarked. Since that time there has been growing interest in Bristol's role in the 'triangular trade', which saw ships leave Bristol filled with goods to purchase slaves, carry those slaves to West Indian plantations, and return to Bristol laden with sugar. Although Colston's principal connection with the slave trade was through the London-based Royal African

Development Control Committee B – 21 February 2024**Application No. 23/04315/LA : Statue Of Edward Colston Colston Avenue Bristol BS1 4UA**

Company, he has come to be seen as the pre-eminent representative of this aspect of Bristol's history.

SOURCES: Dictionary of National Biography; V. Coules, *The Trade: Bristol and the Transatlantic Slave Trade* (2007); Bristol Historic Environment Record; D. Merritt, *Sculpture in Bristol* (2002); <http://johncassidy.org.uk/> accessed on 2 January 2008; R. Winstone, *Bristol in the 1890s* (1960)

REASONS FOR DESIGNATION The statue of Edward Colston is designated at Grade II for the following principal reasons: * A handsome statue, erected in the late C19 to commemorate a late C17 figure; the resulting contrast of styles is handled with confidence * The statue is of particular historical interest, the subject being Edward Colston, Bristol's most famous philanthropist, now also noted for his involvement in the slave trade. * Group value with other Bristol memorials: a statue of Edmund Burke, the Cenotaph, and a drinking fountain commemorating the Industrial and Fine Art Exhibition of 1893"

PROPOSAL

This is an application for Listed Building Consent to move the statue of Edward Colston from Colston Avenue to the M Shed. Listed Building Consent is required because the statue including the pedestal and plinth is Grade II listed. The plinth would remain in situ and a new plaque is proposed.

The applicant has provided the following summary of events leading up to the submission of this application:

"On 7th June 2020, the grade II listed bronze statue of Edward Colston was pulled down from its plinth on Colston Avenue during a Black Lives Matter demonstration. After being rolled through the City Centre, the statue was dumped into the Floating Harbour by a crowd of demonstrators.

The statue was recovered from the harbour and in the summer of 2021 went on display in the museum. While on display, Bristol City Council and the History Commission that had been established by the authority following the events in June, ran a public consultation process with visitors to the exhibition and online. This consultation asked what people thought should now happen to the statue and surviving plinth in the City Centre. The results of this consultation process informed a report by the commission that concluded with 6 recommendations for the future of the statue and plinth."

This application, which is made by Bristol City Council, seeks to implement a number of those recommendations. Specifically, these are as set out in the applicant's statement follows:

Recommendation 1

That the Colston statue enters the permanent collection of the Bristol City Council Museums service.

Recommendation 2

That the statue is preserved in its current state and the opportunity to reflect this in the listing description is explored with Historic England.

Development Control Committee B – 21 February 2024**Application No. 23/04315/LA : Statue Of Edward Colston Colston Avenue Bristol BS1 4UA****Recommendation 3**

That the statue be exhibited, drawing on the principles and practice of the temporary M Shed display where the statue was lying horizontally. That attention is paid to presenting the history in a nuanced, contextualised and engaging way, including information on the broader history of the enslavement of people of African descent.

Recommendation 4

That the former Colston statue plinth, along with the original plaques, remain in place and that a new plaque is installed that briefly and factually explains when and why the statue was put up and taken down.

The following wording for the new plaque is suggested:

“On 13th November 1895, a statue of Edward Colston (1636 - 1721) was unveiled here celebrating him as a city benefactor. In the late twentieth and early twenty-first century, the celebration of Colston was increasingly challenged given his prominent role in the enslavement of African people.

On 7th June 2020, the statue was pulled down during Black Lives Matter protests and rolled into the harbour. Following consultation with the city in 2021, the statue entered the collections of Bristol City Council’s museums.”

It is understood that the applicant sought pre-application advice from Historic England prior to the submission of the application.

RELEVANT PLANNING HISTORY

20/03127/F – Appeal: Temporary art installation for a period of 2 years (retrospective) entitled, ‘A Surge of Power (Jen Reid) 2020’ on the plinth of the former statue of slave trader Edward Colston (grade II listed). (Appeal reference APP/Z0116/W/20/3260461) Appeal against non-determination dismissed 4th August 2021

20/03128/LA – Appeal: Temporary art installation for a period of 2 years (retrospective) entitled, ‘A Surge of Power (Jen Reid) 2020’ on the plinth of the former statue of slave trader Edward Colston (grade II listed). (Appeal reference APP/Z0116/Y/21/3269256) Appeal against non-determination dismissed 4th August 2021

20/02458/LA – A Grade 2-listed statue of Edward Colston is proposed for partial demolition of the metal statue and statue base. The remainder of the pedestal is proposed to be retained. Application cancelled

18/03688/LA – Addition of a new bronze plaque to the stone pedestal. Granted subject to conditions 13th November 2018

07/03469/F – Temporary artwork constructed around the statue of Edward Colston. Granted subject to conditions 12th October 2007

07/03470/LA – Temporary artwork constructed around the statue of Edward Colston. Granted subject to conditions 12th October 2007

01/01753/LA – Maintenance treatment comprising of cleaning and wax treatment of bronze statue and panels and cleaning of stone plinth. Granted subject to conditions 27th July 2001

RESPONSE TO PUBLICITY AND CONSULTATION

A site notice was displayed at the site on 22/11/2023 and a press advertisement was published on 22/11/2023.

There were 4 representations received, comprising 2 objections, 1 neutral comment and 1 comment in support, on the following grounds in summary:

Objections to the application

- Object to the statue being put on display at M Shed for the same reason quoted in the Crown Court for its removal. The statue is offensive in its nature, Colston is unbristolian.
- Whatever one feels of the contested history involved, it 'immortalises' and thereby rewards a heritage crime and act of art vandalism by people flouting Covid rules at the height of the pandemic, showing contempt for the democratic process, and undermining the law - it is deeply offensive to very many Bristolians and others as a result.

Pre-toppling the council had a 'retain and explain' plan for the statue, with planning permission, of the type recommended by Historic England for contested monuments, arrived at with substantial public input and wide support, and aimed at bringing the city together in a better understanding of its history.

Instead of this positive plan, after the toppling and a cynical disinformation campaign and flawed survey, we now have this highly divisive misuse of the remnants of the statue to promote a simplistic polarised, politicised, radicalised and racialised viewpoint also elevating the often semi-literate ahistorical rants of a lawless mob to prominence, while ignoring law abiding dissenting voices across the city - many of whom have a wealth of historical knowledge.

Also object to the proposed wording for the additional plaque for the empty plinth for the reasons and suggest a reworded version that is fit for purpose.

Neutral comment

- Comment received from Chair of Bristol Civic Society's Blue Plaques Panel with a request for a condition to be added that a design showing the wording is submitted.

Comment in support of the application

- Comment received from Chair of the History Commission advising that the Commission held an extensive consultation with the city in the summer and autumn of 2021, linked with the temporary display of the statue in the M-Shed museum.

Just under 14000 people responded - around half from Bristol - with a clear majority supportive of moving the statue into the permanent collection of the M-Shed museum and putting it on display there. 80% of Bristol respondents wished to see the statue in the M-Shed (with smaller numbers - c. 12% of the Bristol sample wanted the statue back on the plinth; c . 4% of the Bristol sample wanted the statue back in the harbour or destroyed - wanting the statue to end up somewhere else).

One thing that was important was ensuring that these voices were broadly representative of the city as a whole.

The proposal to move the statue from Colston Avenue to the M Shed museum is one that meets with widespread approval from those who responded in their thousands to the consultation in 2021.

From reading comments most people in the city feel that the statue is too problematic to sit atop a plinth in the city centre, but remains of historical value (including the recent history of its toppling) and so should be placed into a museum where its long and contested history can be explained in more words than a plaque allows, and in a place where people can choose to visit.

Consultees

Historic England

“Summary

In June 2020, the statue of Edward Colston was pulled down and rolled into Bristol’s Floating Harbour during a Black Lives Matter protest. Subsequently the City Council arranged for the statue to be retrieved from the waters and for it and the fallen capstone from the plinth to be taken to Bristol Museums.

The statue of Edward Colston has become a touchstone for Bristol’s connections to the transatlantic trade in enslaved people. The proposal to regularise its removal from its plinth would cause a high degree of harm to the listed ensemble of plinth and statue; this would be substantial in the language of the National Planning Policy Framework (NPPF). Planning policy and legislation sets a high bar for justifying such a proposal.

While it will be for the decision-maker to determine whether the proposals would deliver substantial public benefits sufficient to outweigh the substantial harm it would entail, Historic England recognises both that the Council has undertaken a wide-ranging appraisal of the sentiment of Bristolians towards the future of Colston’s statue, and that it believes that the removal of the statue is important to the well-being of the city. We also note the Council’s commitment to permanently displaying the statue in the M Shed Museum.

Historic England Advice

Significance

Legally, the statue of Colston and its plinth remain intact and in situ, and together form a monument listed at grade II on account of its historic and artistic interest. This provides the correct starting point in planning terms for consideration of the current proposals, and not the current de facto position, in which the statue has been removed.

Edward Colston played a central part in the trade in enslaved people of the late 17th and early 18th centuries. His engagement in this trade was both sustained and direct. In the 1680s and early 1690s Colston was a member of the Royal African Company, and for a year was its principal official. The company had a monopoly of trade with Africa and thus of the slave trade. Colston’s involvement in the trade in enslaved people continued after he left the company.

During Colston's membership of the Royal African Company, it is estimated that the company transported over 84,000 enslaved people from Africa to the West Indies and Americas. As many as 19,000 people may have died during the Atlantic crossing - the Middle Passage. Conditions for those who survived were harsh, and life expectancy short.

Colston gave a substantial part of his wealth to philanthropy. His chief benefactions were to Bristol institutions. They included almshouses, schools and churches.

In 1895 Colston's benefactions were recognised by the erection of a monument to his memory. It was intended to commemorate Colston's substantial benefactions to Bristol, and to commemorate his philanthropy. It was commissioned by a committee organised by J.W. Arrowsmith, a Bristol printer and publisher and a promoter of the Industrial and Fine Art Exhibition held on this site in 1893-94.

The monument was the work of John Cassidy (1860-1939). Cassidy was born in Ireland, trained in Milan and worked throughout his career in Manchester. Much of his work comprised busts and plaques celebrating commercial and cultural figures in Manchester and the surrounding areas. After the First World War he designed a series of war memorials.

Cassidy's monument to Colston is an eclectic work, characteristic of the period. It comprises a substantial plinth which supported a full-length figure of Colston.

Colston is portrayed deep in thought, his head supported by his left hand and arm, which are in turn supported by his right hand and a long staff. He wears late 17th century dress. The portrait combines sensitivity in the modelling and mood of the face with an illustrative character in its treatment of the clothing.

The plinth on which the statue was set is Baroque in its general character. Angled projections at the base support dolphins - Colston's emblems. Inverted volutes articulate the narrowing of the main body of the plinth to the cap upon which the statue itself was set. The principal surface on each side is set with a bronze plaque, which commemorate Colston's life.

The ensemble of statue and plinth was listed at grade II in 1977. The monument's entry on the National Heritage List for England, which was revised in 2007, identifies the following reasons for the monument's designation:

- a) "A handsome statue, erected in the late C19 to commemorate a late C17 figure; the resulting contrast of styles is handled with confidence";
- b) "The statue is of particular historical interest, the subject being Edward Colston, Bristol's most famous philanthropist, now also noted for his involvement in the slave trade";
- c) "Group value with other Bristol memorials: a statue of Edmund Burke, the Cenotaph, and a drinking fountain commemorating the Industrial and Fine Art Exhibition of 1893".

From this it may be concluded that the significance of the Colston monument, in the language of the NPPF, lies in its artistic and historic interest, both of which are considerable.

Summary of proposals

The current proposals would regularise the removal of the statue from its plinth. The statue, which has been conserved in its current state, would be displayed in the M Shed, one of the City's museums, where the fallen capstone from the top of the plinth would also be kept. An interpretive panel would be attached to the plinth itself, which would remain in situ, and the plinth would be used for temporary installations.

Proposals for a cultural programme for the site of the plinth do not form part of the listed building consent application.

Impact of the proposed development

The removal of the statue of Colston from the monument of which it forms part would severely impair the monument's significance.

The statue is the *raison d'être* of the monument itself. It represents the man the monument commemorates and is the most artistically important part of the whole. The removal of the statue would take away much of the monument's historic and artistic interest.

This notwithstanding, the plinth itself would remain of some interest. It is a substantial structure, carefully composed and richly adorned, and is of historic and artistic interest in its own right.

Planning legislation and policy context

The NPPF sets out three overarching objectives at paragraph 8, of which two are relevant to this case.

One of these is "a social objective - to support strong, vibrant and healthy communities, by ensuring that a sufficient number and range of homes can be provided to meet the needs of present and future generations; and by fostering well-designed, beautiful and safe places, with accessible services and open spaces that reflect current and future needs and support communities' health, social and cultural well-being".

Another is "an environmental objective - to protect and enhance our natural, built and historic environment".

The NPPF explains that heritage assets "are an irreplaceable resource, and should be conserved in a manner appropriate to their significance, so that they can be enjoyed for their contribution to the quality of life of existing and future generations" (189).

Paragraph 196 makes clear that "where there is evidence of deliberate neglect of, or damage to, a heritage asset, the deteriorated state of the heritage asset should not be taken into account in any decision".

The next paragraph goes on to say that "in determining applications, local planning authorities should take account of ... the desirability of sustaining and enhancing the significance of heritage assets" and also "the positive contribution that conservation of heritage assets can make to sustainable communities" (197, a, b).

Paragraph 198 specifically addresses applications to remove historic statues. It states that "in considering any applications to remove or alter a historic statue, plaque, memorial or monument (whether listed or not), local planning authorities

should have regard to the importance of their retention in situ and, where appropriate, of explaining their historic and social context rather than removal.”

The NPPF continues, “when considering the impact of a proposed development on the significance of a designated heritage asset, great weight should be given to the asset’s conservation... This is irrespective of whether any potential harm amounts to substantial harm, total loss or less than substantial harm to its significance” (paragraph 199).

Paragraph 200 sets out that “any harm to, or loss of, the significance of a designated heritage asset ... should require clear and convincing justification. Substantial harm to or loss of ... grade II listed buildings ... should be exceptional”.

Finally, paragraph 201 explains that “where a proposed development will lead to substantial harm to (or total loss of significance of) a designated heritage asset, local planning authorities should refuse consent, unless it can be demonstrated that the substantial harm or total loss is necessary to achieve substantial public benefits that outweigh that harm or loss, or unless four criteria are all met”.

In a Written Ministerial Statement made to Parliament on 18 January 2021, the then Secretary of State for Housing, Communities and Local Government, Robert Jenrick, stated about statues and monuments that “decisions to remove any such heritage assets owned by a local authority should be taken in accordance with its constitution, following consultation with the local community and interested parties, and the rationale for a decision to remove should be transparent.” This statement of government policy is a material consideration when deciding applications.

Historic England Position

The City Council’s proposal is to confirm the removal of Colston’s statue from its plinth, and conserve it within the City’s collection. Historic England recognises the very difficult history of which the statue has become the touchstone, but considers that the statue’s removal would cause substantial harm to the listed structure formed by statue and plinth. The policies referred to above would be engaged.

Most obviously, the City Council’s proposal runs counter to the importance of retaining statues in situ and interpreting them (NPPF, 198). It must also be tested against the requirement that local planning authorities refuse proposals which would cause substantial harm to the significance of a designated heritage asset, unless that harm would be outweighed by substantial public benefits, or meet all of four criteria (NPPF, 201). The strength of this policy flows from the great weight to be accorded to the conservation of the significance of designated heritage assets (NPPF, 199).

In this case, in considering the NPPF’s policy in respect of substantial harm, the former test is the relevant one; the criteria are not applicable. In other words, the proposal must be justified by the public benefits it would provide, or not at all.

While it will be for the Local Authority, as decision-maker, to determine whether the proposal would deliver substantial public benefits sufficient to outweigh the substantial harm it would entail, Historic England can make a number of observations on the nature of the arguments put forward and the policies engaged.

At the heart of the Council's justification is the argument that regularising the removal of Colston's statue from the monument is of great importance to Bristol's well-being. This argument rests on an appraisal of the wishes of the City, a judgement about the consequences of reinstating the statue and a commitment to explain Colston's role as both slave trader and benefactor.

Since 2020, Bristol City Council has deliberated on the future of the statue and the monument of which it forms part. These deliberations have been informed by the work of the 'We Are Bristol History Commission', established by the Mayor in the immediate aftermath of events in June 2020.

Through the work of the Bristol History Commission, Bristol City Council has undertaken a wide-ranging appraisal of the sentiment of Bristolians towards the future of Colston's statue. The Commission reported that four out of five Bristolians thought the statue should be kept in a museum; seven of ten supported the addition of a plaque to the plinth to reflect the events of 2020; six of ten supported the use of the plinth for temporary artworks; and five of eight approved the pulling down of the statue.

The Commission's report does make clear that opinion, although broadly in favour of the points set out above, is also divided. While 65% of Bristolians were positive about what had happened, 36% - a substantial minority - felt negatively about the pulling down of the statue.

It is not for Historic England to gauge the weight to be accorded to the Commission's conclusions, but we acknowledge the seriousness with which this exercise has been conducted. This approach seems wholly in accordance with the Secretary of State's requirement that councils consult communities when considering such proposals.

The obverse of the Commission's conclusions is the Council's judgement that the "reinstatement of the statue to Edward Colston... would cause additional upset and disgust and potentially lead to further public order and health and safety risks as well as damage community cohesion".

Again, it is not for Historic England to gauge this judgement, although given the climate of public opinion in the city, as demonstrated by the consultation process that took place as part of the History Commission report, it must be taken seriously.

The Framework recognises that the social objective of the planning system, one of the three objectives which support the achievement of sustainable development, is "to support strong, vibrant and healthy communities" (NPPF, 8, b). Equally, the Framework requires local planning authorities to take account of "the positive contribution that conservation of heritage assets can make to sustainable communities" (NPPF, 197, b). In this case, the City considers in effect that the retention - practically, the reinstatement - of the statue would run counter to the social objective of the planning system.

The final part of the justification rests on the Council's commitment to contextualise and explain the role of Colston as both slave trader and benefactor through the display of the statue in the M Shed Museum and the installation of a new plaque on the remaining plinth. The impact of the installation of a new plaque on the plinth to the significance of the listed structure would be very modest. Any harm would be negligible.

Development Control Committee B – 21 February 2024**Application No. 23/04315/LA : Statue Of Edward Colston Colston Avenue Bristol BS1 4UA**

We recognise the potential of these proposals to contextualise the empty plinth and the fallen statue, enabling a deeper understanding of Colston's difficult past.

In summary, the most important part of the City Council's proposal would be the permanent removal of the statue of Colston - which remains, in law, in place - from the listed structure. This would entail substantial harm to that listed structure, and it will be for the decision-maker to determine whether the Council's justification would provide substantial public benefits to outweigh the harm that removal would entail. Should it be found to do so, it would be reasonable to conclude that the other policy tests referred to above would be met, including that requiring the consideration of the importance of retaining statues in situ, and, where appropriate, explaining their historic and social context (NPPF, 198).

Conclusion

We recognise the pain that Colston's role in the transatlantic trade in enslaved people has caused.

The monument to Edward Colston, a slave trader and benefactor, is of historic and artistic interest. Its permanent removal from its plinth would cause a high degree of harm to the significance of the listed ensemble of plinth and statue. This harm would be 'substantial' in the language of the NPPF. We welcome the work of the Bristol History Commission, and recognise the wide-ranging approach to the consultation, which has informed these proposals. Ultimately, however, it will be for Bristol City Council as the decision-maker to determine whether the proposals would be justified."

National Amenity Societies

No comments received.

Conservation Advisory Panel

"The Panel recognised that the future location of the statue was a very sensitive issue, and this was discussed at length. The Panel regret the damage and harm that has been caused to this heritage asset, and whilst they would prefer that the statue was replaced and retained in its original location, with an explanation provided on its background, they acknowledged that this was unlikely to be feasible in practice. It was agreed that the statue should not be cleaned or repaired, but should for preference be displayed in an upright position in the Museum."

Bristol City Council Conservation

"Summary:

The proposed development would be harmful to designated heritage assets; that harm and the public benefit arising from it are wholly exceptional. Harm would be partially mitigated through the proposed works. On balance, development would be significantly in the public interest and this is given very considerable weight. Despite the great weight required in the conservation of the assets, the public benefit outweighs the degree of harm posed. We recommend the decision-maker approve development subject to conditions.

Significance:

Development would directly impact the architectural and historic interest of the Grade II Listed statue and base, and the character of the City Centre and College Green Conservation Area. The group value of the collection of Listed civic monuments along the Centre would also have their setting impacted; these include the Grade II Listed statue of Burke, drinking fountain commemorative of the 1891 exhibition, and the cenotaph.

The statue of Edward Colston and its plinth were erected posthumously in 1895, 174 years after his death. The statue was commissioned to stand in the new park laid out following the culverting of the River From. This presented a new opportunity to host civic adornments in one of the few open public spaces then available in the city centre. The selection of Colston as a subject for a statue was championed by JW Arrowsmith, whose Printing business adjoined the new open space at the head of the former quay. The choice of Colston, a Tory MP, appears to have been, at least partly, a political reaction to the planned and executed erection of a statue to the eminent Whig MP, Edmund Burke, by the Wills family, in the same area.

Architecturally, it's a prominent, monumental structure designed and executed in form, detail, and materials intended to impress. The plinth is highly ornate with attractive stepped form and bronze embellishments expressing the opulence and wealth of the age in which it was erected. The statue, in contrast, has a hunched, sullen and downbeat pose, unlike the posturing classical stance adopted in Burke's statue. The modelling and bronze casting are particularly high quality.

Significance of the statue and plinth is considered to have been considerably heightened by events of 7.6.20 when it received international attention following toppling during an anti-racism protest. Edward Colston's involvement in the Transatlantic slave trade, a long-established fact in Bristol, became nationally known through the pulling-down of the statue from its plinth and throwing into the docks. It inspired citizen action against totems of intolerance across the world. Statue and plinth, although presently separated, are now historically significant in new ways to those intended by its creators.

The National Planning Policy Framework (NPPF) is clear, that: '196. Where there is evidence of deliberate neglect of, or damage to, a heritage asset, the deteriorated state of the heritage asset should not be taken into account in any decision' The toppling of the statue from the plinth was clearly a deliberate act of damage, so the deteriorated state cannot be taken into account in the planning decision. This creates a paradox, where a degree of historic significance of the asset now arises from its effective separation. Whilst the NPPF states that the deteriorated state cannot be taken into account in the decision, it does not preclude that damage having increased the heritage significance or the assessment of that significance as part of assessing against the tests of the NPPF.

Proposals:

This Listed building application seeks to formally remove the statue and base from the plinth, and lodge them in the collections of the Council-owned M-Shed museum. The Museum is Accredited by the Arts Council England and is required to maintain a collections care and conservation policy, and a collections care and conservation plan; following lodging in the collections, the statue would be protected by those provisions.

Proposals also include for the affixing of a new plaque to the Grade II Listed plinth, recording the role of Edward Colston in slavery, and commemorating the pulling down of the statue in 2020. Drawings or other material showing the design of this plaque are not provided in the application, though an intended location and draft wording for the plaque is included in the supporting statements.

Assessment and potential mitigation

Is there harm posed by the development? (NPPF para 200):

As noted above, the NPPF the 'deteriorated state' of the asset cannot be taken into account in decision making, though it's not clear how damage that has amplified significance should be dealt with; To what extent has its 'state' been deteriorated or elevated by unlawful actions? It is undoubted that physical harm has occurred to the Listed structure. The ripping away of the statue has caused material damage to the plinth, and the statue itself is in a technically irreparable condition. The physical damage is irreversible. The deteriorated state of the heritage asset is not to be taken into account in any decision, that is to say, the present state of the asset is a separate consideration from the procedural assessment of heritage significance against the other tests of the NPPF, and the assessment of significance, harm, justification, and balancing harm against public benefit remain necessary parts of the

The NPPF is explicit that assessment should take into account 'the desirability of sustaining and enhancing the 'significance' of heritage assets' in our assessment rather than their physical 'state'. Accepting only the previous physical condition of the structure, we would be forced to disregard the heritage significance as it presently exists. The NPPF is clear that significance should underpin the decision-making process and that the physical state of the asset should not.

The NPPF requires harm to significance to be established. Historic England define significance as 'a collective term for the sum of all the heritage values attached to a place, be it a building an archaeological site or a larger historic area such as a whole village or landscape.' It defines heritage values as being:

Evidential value: the potential of a place to yield evidence about past human activity.

Historical value: the ways in which past people, events and aspects of life can be connected through a place to the present - it tends to be illustrative or associative.

Aesthetic value: the ways in which people draw sensory and intellectual stimulation from a place.

Communal value: the meanings of a place for the people who relate to it, or for whom it figures in their collective experience or memory.

Harm would occur to the Listed statue and plinth where its heritage values were undermined. To summarise these individually:

Evidential value of the structure arises from its location in a prominent civic site, and how the construction and fabrication of the statue and plinth help inform our understanding of historic techniques. The large chunk taken out of the plinth moulding evidences the aggressive method of the statue's removal. Despite the present intention to separate the statue from the plinth, the evidential value would remain unaffected, with the location continuing to be marked by the masonry plinth, and the bronze casting secured in a museum collection where it would be available for inspection and protected by the collection management policies which would ensure better preservation than in the intended location.

The historical value derives from the celebration of Edward Colston as a significant figure in Bristol's past, from the physical expression of the social and political context in which the statue and plinth was erected, and from the actions of 2020 that brought it to international interest. It is argued that greater historic and commemorative value now resides in the plinth as symbolically vacant. Colston's commemoration by the Victorians remains explicit in the remaining plinth and plaques, though without the physical presence of the effigy itself.

The statue and plinth have aesthetic value together. They are a traditional coupling of a masonry pedestal and elevated representation of a celebrated personage that derives ultimately from the traditions of the Classical world; separated this allusion is damaged. Harmonious composition and proportions of both elements would be significantly impacted by the loss of the statue. The visually attractive, lifelike, and high-quality modelling of the statue would be entirely lost to the Listed building, but preserved elsewhere. The complementing materials of dark patinated statue, reliefs, and dolphins set against the bright white Portland Stone would be undermined, though not entirely lost. The stepped form of the plinth would be impacted by the loss of its uppermost masonry section, the statue base, which gave added stature and monumentality to the whole composition. The foreshortened plinth would retain a degree of aesthetic value in the late-Victorian dolphins and plaques, and the generally attractive proportions of the remaining structure, however, it would not have the same visual and monumental prominence of the complete structure.

Communal value contributes to significance through the collective memory and experience. The presence of a statue of a prominent slave trader is offensive to many, whilst Colston's charitable works are well memorialised on the plinth and elsewhere in the city. In the present day, consciousness of the statue and works of Colston were most frequently experienced when interventions to highlight Colston's role in the slave trade, artworks or new plaques, or a continuing campaign to address Colston's role became newsworthy events. Most Bristolians will have experienced the statue and plinth as an historically controversial monument, whatever their view might be on Colston as a man. Despite dating from the 19th Century, what the structure represented of 17th and 18th Century was how it was most frequently appreciated. The toppling of the statue in controversial circumstances has escalated communal value way beyond the boundaries of the city, with international interest being focussed on the statue, plinth, and notable historic events of June 2020.

In conclusion, whilst the aesthetic value has been significantly impacted, and the traditional historic and evidential values altered, the actual historic significance of the statue and plinth have been increased through the actions of 2020 regardless of its current state.

In considering whether the asset would be harmed by development it is also worthwhile returning to the Planning (Listed building and Conservation Areas) Act 1990. The act allows for buildings to be added to the national list and protected for their 'special architectural and historic interest'. The terminology here is different from that of the NPPF and Historic England's heritage values, and lacks the same breadth and nuance. The Act prohibits 'alteration or extension in any manner which would affect its character as a building of special architectural or historic interest, unless the works are authorised' by the Local Authority. The protection of the architectural and historic characteristics of the statue and plinth are therefore the objective of the Act. The statue and plinth have been moved several times within the broad area of the modern Centre without the architectural and historic character being impacted. This demonstrates the location of statue and plinth has little bearing on its special historic

interest or character, and that those characteristics might be protected and sustained in alternative locations.

The NPPF requires decision making to 'sustain or enhance' heritage significance. Where development would fail in those ambitions it can be judged to pose harm. The development proposed, to remove the statue from the plinth and provide new interpretation, would ensure the present significance is sustained and enhanced through the new interpretive plaque. If the statue was still in place and the present application refused, the overall heritage significance would be less than it is currently experienced.

In summary, certain of the heritage values underpinning significance would be harmed by the proposed development, others sustained and enhanced. Conversely, should development be refused, the heritage values would be harmed in other ways. However, the statue is an integral and key component of the Listed building and its removal is, on balance, considered to cause harm to significance. The proposals to protect the statue in an alternative location and provide interpretation on the standing plinth help mitigate that harm. Overall, therefore, the harm to significance is not of a substantial degree.

Has clear and convincing justification been given for the harm? (NPPF para 200):

Before now, Historic England have often posed the question, how else could the purported public benefits be secured without harm to the asset? It's clear in this instance, that the totality of the public benefits could only be achieved through the removal of the statue to a secure public collection. Allowing the statue to remain on the plinth would expose it to further attack, damage and the risk of provoking further civil unrest. It is no longer possible to protect the architectural and historic interest with the statue and base attached to the plinth. Whilst the approach would usually be 'retain and explain' assets of contested heritage, the now-international profile of the statue and broader understanding of Colston's history in slave trading brought about for the 2020 actions, have focussed negative attention on the celebration of Colston, and retention would be enticement to future acts of a similar violent nature.

The current condition of the bronze casting is very poor. Whilst it's damaged state cannot form part of our decision making, the statue itself cannot continue to form part of the Listed asset as a whole. We are satisfied that, due to the irreparable and unsafe condition of the statue, it would require recasting if it were to remain integral to the plinth. Any replacement of the statue would not have the same heritage value as the original Victorian casting, even if the appearance could be replicated. With a facsimile in place of the original, the original integrity could not be fully restored. The replacement would remain provocative, the target of vandalism and antisocial behaviour, and the potential focus of civil unrest. A statue of Colston remaining on the plinth is not a reasonable expectation.

What are the purported public benefits? (NPPF para 202):

The NPPF requires public benefits to be of an economic, social, or environmental benefit. There is an overwhelming degree of public benefit in the removal of the statue. It would minimise the potential for criminal damage and vandalism of the Listed structure. The removal of the statue would encourage greater community cohesion, where the presence of the statue of Colston in a highly trafficked public place has stoked division. Development would help repair relationships between the

Council and communities, for whom years of inaction have caused upset and alienation.

It would ensure the statue forms part of a secure accredited museum collection with enhanced conservation requirements, where people have the option to view it should they choose to. It would allow for the interpretation of contested heritage through the retention and contextualisation of the plinth with a new plaque, and the further explanation of the heritage significance as part of museum collections. The enhanced interpretation of statue and plinth would have an additional heritage benefit, where the international significance of statue and plinth could be greatly enhanced.

There are economic benefits where the city's tourism industry would benefit from the international attention from the statue and its felling, though it is difficult to attribute a specific degree of weight in this aspect. There would be economic benefit too, in removing the significant financial obligation on the local taxpayer of having to replace the statue where the original is irreparable.

Do public benefits outweigh harm where that harm has clear and convincing justification? (NPPF para 202)

It's clear there are exceptional circumstances around the current application. Significant, or 'great' weight is required in the planning balance in favour of conservation of designated assets. Historic England define conservation as "The process of maintaining and managing change to a heritage asset in a way that sustains and where appropriate enhances its significance." We have indicated above that we consider that consenting to the removal of the statue from its plinth would enable change to be managed in a way that could enhance the heritage values that underpin significance.

We acknowledge the harm that would be caused to significance by consenting removal of substantial proportion of the Listed structure, a key element of its significance, and the resultant loss or aesthetic value and architectural character of the whole composition. That the present state is deteriorated, permanently damaged, cannot be taken into account in forming a recommendation, however the NPPF separates consideration of the deteriorated state of the asset from the assessment of significance. As defined by Historic England, the heritage values underpinning significance are not entirely dependent on the objective physical state of the asset. They allow for intangible aspects to contribute to special importance, how an asset is experienced and appreciated, its meanings and memories, how it intellectually stimulates and allows for interpretation. The significance would be enriched by formalising removal of the statue of Colston.

We consider the harm posed by development is justifiable, and that there would be very significant and substantial public benefits to the removal of the statue from the public realm, its future protection in an accredited museum collection, the preservation of the plinth in-situ, and the addition of an interpretive plaque. The substantial public benefits outweigh the harm posed. In this assessment we have placed great weight in conservation of the heritage asset, that is, the sustaining and enhancing of its significance.

Following, and in reaction to, the widely publicised and controversial felling of the statue, its dropping in the harbour, and subsequent national and international attention focussed on contested heritage, the Government made a specific addition to the NPPF:

'198. In considering any applications to remove or alter a historic statue, plaque, memorial, or monument (whether listed or not), local planning authorities should have regard to the importance of their retention in situ and, where appropriate, of explaining their historic and social context rather than removal.'

We have regarded the importance of retaining the statue and plinth together in situ, and the required 'great weight' required in the conservation of designated heritage assets. We welcome the Government's recognition of the importance of the historic environment and the need to protect it unharmed. We have agreed that explaining of the significance of the statue through a permanent plaque installed on the plinth is wholly appropriate and offers a degree of mitigation for the harm that would arise from development.

Recommendation for decision:

Setting aside the current deteriorated state of the Listed structure, the public benefits that would be brought about by development are substantial in degree. Any harm posed to significance ' the collective heritage values ' is judged to be wholly exceptional in this case, and justified in being overwhelmingly in the public interest. The harm posed to significance would be permanent, but we do not consider that it impacts the heritage values to be impaired to a substantial degree. Harm would be mitigated somewhat in the setting up of a new interpretive plaque and the protection of the statue of Colston in accredited museum collections.

The significant public benefits, social and to a lesser extent, brought about by development would be of such a degree that we consider they outweigh the harm posed; this is despite placing great weight in the planning balance in favour of conservation.

We recommend the following:

' That Listed building consent is granted subject to conditions.

' That the Secretary of State is notified of the Local Authorities intended decision

' That Historic England are invited to amend the Listing description of the plinth to omit the statue element and explain the amended the historic interest of the remaining plinth.

Should the local Authority decide to approve development we request that the following conditions are appended:

Prior to commencement of the relevant element, the following detailed drawings shall be submitted to the Local Authority and approved in writing:

- a) 1:5 section and elevation drawings of the proposed plaque showing it's intended materials, profiles, design, fixings, typeface, and wording
- b) 1:10 elevation detail of the plinth showing the location of the proposed plaque and its fixings

Development should be completed in accordance with the approved drawings.

Reason: To safeguard the architectural and historic interest of the Listed structure and the special character of the Conservation Area.

Prior to completion of the works, written confirmation must be provided to the Local Authority that the statue and statue base have been formally entered as accessioned artefacts in the Bristol Museums collection.

Reason: To ensure the public benefits of development are secured in their totality.

Development Control Committee B – 21 February 2024**Application No. 23/04315/LA : Statue Of Edward Colston Colston Avenue Bristol BS1 4UA**

Prior to the Completion of the works, a management plan for the display and interpretation of the statue and statue base as part of Bristol Museums collections should be submitted to the Local Authority and approved in writing.

Reason: To ensure the public benefits of development are secured in their totality.

Development must be fully implemented within three years of consent.

Reason: To ensure the public benefits of development are secured in their totality.”

Arrangements for handling heritage applications Direction 2021

As noted above, notification of the application has been given to Historic England and the National Amenity societies. Based on the proposals, the comments received and noting the requirements of Arrangements for handling heritage applications Direction 2021, it is not considered that there is a need to refer the application to the Secretary of State.

EQUALITIES ASSESSMENT

The public sector equalities duty is engaged through the public body decision making process.

Section 149 of the Equalities Act 2010 provides that a public authority must in the exercise of its functions have due regard to:-

- (a) eliminate discrimination, harassment, victimisation and any other conduct prohibited under the Act
- (b) advance equality of opportunity between persons who share a relevant protected characteristic and persons who do not share it
- (c) foster good relationships between persons who share a relevant characteristic and those who do not share it.

During the determination of this application due regard has been given to the impact of the scheme upon people who share the protected characteristics of age, disability, gender reassignment, marriage and civil partnership, pregnancy and maternity, race, religion or belief, sex and sexual orientation.

Officers have had due regard to the Public Sector Equality Duty contained in the Equality Act 2010 when making the assessment set out in this report.

An Equalities Impact Assessment has been undertaken in relation to this decision which has been reviewed by the Council's Equality and Inclusion Team. The Assessment considers whether the proposal would have any potentially adverse impacts on people based on their protected or other relevant characteristics. Disproportionate impacts on those with protected characteristics has not been indicated by the Assessment. The Assessment considers that the proposal would have the potential to create benefits in terms of advancing equality of opportunity between people who share a protected characteristic and those who don't, and also through the fostering good relations between people who share a protected characteristic and those who don't. It would also enable opportunity for a wide variety of people to learn about the history of Bristol through the display of the statue in the M Shed with associated accessible material.

RELEVANT POLICY

The following are considered to be relevant:

Development Control Committee B – 21 February 2024**Application No. 23/04315/LA : Statue Of Edward Colston Colston Avenue Bristol BS1 4UA**

National Planning Policy Framework (NPPF) – December 2023

Bristol Local Plan comprising Core Strategy (Adopted June 2011), Site Allocations and Development Management Policies (Adopted July 2014) and (as appropriate) the Bristol Central Area Plan (Adopted March 2015)

Other relevant documents/guidance:

Written Ministerial Statement by The Secretary of State for Housing, Communities and Local Government “Planning and Heritage: Historic Statues, Plaques, Memorials and Monuments” Monday 18 January 2021

Historic England: Checklist to Help Local Authorities Deal With Contested Heritage Decisions

In determining this application, the Local Planning Authority has had regard to all relevant policies of the Bristol Local Plan and relevant guidance.

COMMUNITY ENGAGEMENT

Community consultation is not a formal requirement for non-major applications for Listed Building Consent such as this.

By way of background, the applicant has however referred to the public consultation that has been undertaken relating to the proposal, and in a section headed “Statement of Community Involvement” contained within the submitted “Heritage and design statement” a summary of the key results from the History Commission’s work has been provided.

The applicant submits that the approach for both the statue and plinth as set out by the application is the result of an extensive city wide consultation as detailed in ‘The Colston Statue what next?’ History Commission Report. The ‘We Are Bristol’ History Commission was set up in September 2020 by Marvin Rees, Mayor of Bristol, after the pulling down of the statue of Edward Colston in the summer.

In the summer of 2021, the ‘We are Bristol’ History Commission consulted with the public about the future of the Colston statue and the Colston plinth. People had a chance to see the statue and learn about its history in a temporary display at the M Shed museum, as well as view the display online. Alongside the display was a survey that invited people from Bristol and beyond to share their views on a number of questions.

This survey was a chance for people to help to decide what happens to the statue and plinth. The Mayor asked the History Commission to review the consultation and offer a number of recommendations in the light of it. The ‘We are Bristol’ History Commission Full Report titled The Colston Statue: What Next? summarizes the findings and also suggests what might happen next.

The applicant submits that key results from this consultation relevant to this application were that:

- 80% of respondents agreed that the statue should be displayed in a museum
- 70% agreed that a new plaque should be added to the plinth
- 14,000 people responded to the consultation from a good representative sample of the city population, over 50% of whom were from BS postcodes (History Commission short report pages 10-15)

KEY ISSUE**IS THE HARM TO THE SIGNIFICANCE OF THE GRADE II LISTED BUILDING ACCEPTABLE?****Legislation and Policy**

Under the Planning (Listed Buildings and Conservation Areas) Act 1990, listed building consent from the local planning authority is required for the removal or alteration of a statue, plaque, memorial or monument which is designated as a listed building, or which forms part of a listed building, where it affects the special historic or architectural character of the listed building.

Section 16 of the Planning (Listed Buildings and Conservation Areas) Act 1990 states that in considering whether to grant listed building consent for any works the local planning authority shall have special regard to the desirability of preserving the building or its setting or any features of special architectural or historic interest which it possesses.

There is also a general duty in respect of conservation areas when exercising planning functions under Section 72 of the Planning (Listed Buildings and Conservation Areas) Act 1990, which states that “special attention shall be paid to the desirability of preserving or enhancing the character or appearance of that area.”

Bristol Core Strategy (2011) Policy BCS22 seeks to ensure that development proposals safeguard or enhance heritage assets in the city with Policy DM31 in the Site Allocations and Development Management Policies (2014) expressing that alterations to buildings should preserve or enhance historic settings. Policy BCS21 also requires new development in Bristol to deliver high quality urban design and sets out criteria to measure developments against including the need for development to contribute positively to an area's character and identity, creating or reinforcing local distinctiveness.

Policy DM26 more specifically states that the design of development proposals should contribute towards local character and distinctiveness by responding appropriately to the height, scale, massing, shape, form and proportion of existing buildings, building lines, skylines and roofscapes. Policy DM27 further expresses that the layout, form, pattern and arrangement of streets, buildings and landscapes should contribute towards to creation of quality urban space and that the height, scale and massing of development should be appropriate to the immediate context, site constraints, character of adjoining streets and spaces and setting. Policy DM30 further states that any extensions and alterations to existing buildings should respect the siting, scale, form, proportions, materials and overall design and character of the host building and broader street scene. DM30 further states that extensions should be physically and visually subservient to the host building, including its roof form.

Section 2 of the NPPF sets out the aim of achieving sustainable development and Paragraph 8 describes three overarching objectives for the planning system. These objectives are as follows:

- an economic objective – to help build a strong, responsive and competitive economy, by ensuring that sufficient land of the right types is available in the right places and at the right time to support growth, innovation and improved productivity; and by identifying and coordinating the provision of infrastructure
- a social objective – to support strong, vibrant and healthy communities, by ensuring that a sufficient number and range of homes can be provided to meet the needs of

present and future generations; and by fostering well-designed beautiful and safe places, with accessible services and open spaces that reflect current and future needs and support communities' health, social and cultural well-being; and

- an environmental objective – to protect and enhance our natural, built and historic environment; including making effective use of land, improving biodiversity, using natural resources prudently, minimising waste and pollution, and mitigating and adapting to climate change, including moving to a low carbon economy.

The following assessment of the proposed works has been undertaken having regard to Section 16 of the NPPF, "Conserving and enhancing the historic environment".

Paragraph 195 of the NPPF states that heritage assets (including sites and buildings of local historic value to those of the highest significance) are "an irreplaceable resource, and should be conserved in a manner appropriate to their significance, so that they can be enjoyed for their contribution to the quality of life of existing and future generations."

What is the Significance of the Heritage Asset? (Paragraphs 200 and 201 of the NPPF)

When determining applications affecting heritage assets, the NPPF requires through Paragraph 200, that local planning authorities should require an applicant to describe the significance of any heritage assets affected, including any contribution made by their setting.

The NPPF defines "significance" as "the value of a heritage asset to this and future generations because of its heritage interest. The interest may be archaeological, architectural, artistic or historic. Significance derives not only from a heritage asset's physical presence but also from its setting".

The applicant has submitted a Heritage and Design Statement. This includes information regarding historic significance of the specific asset, which is the statue and plinth. This is considered to be sufficient to understand the potential impact of the proposal on the asset's significance. The information provided by the applicant regarding significance is provided in three sections: Edward Colston; The statue; Significance following 7th June 2020.

The applicant has set out the following in relation to the significance of the asset following 7th June 2020:

"The actions in June 2020 has caused a high degree of harm to the asset's significance. The direct connection between the statue and the plinth as well as the statue's setting within the College Green Conservation Area adjacent to several other designated monuments has obviously now been lost.

However, the events of 7th June 2020 reached a global audience bringing international recognition to Bristol, Edward Colston, contested heritage in general and wider injustices.

The now fallen statue and empty plinth are monuments to an international story about enslavement, misguided Victorian commemoration, and modern reactions to injustice.

However, the historic significance of both statue and plinth has now arguably increased. They will always be connected with the moment the statue commemorating a man who had direct connections with the enslavement, torture and death of thousands of people was torn down by demonstrators.

In the weeks and months since, the plinth and surrounding public realm has become a dynamic space, being the focus of conversations and interventions such as the Jen Reid statue and other temporary pieces.”

Paragraph 201 of the NPPF states that Local planning authorities should “identify and assess the particular significance of any heritage asset that may be affected by a proposal (including by development affecting the setting of a heritage asset) taking account of the available evidence and any necessary expertise. They should take this into account when considering the impact of a proposal on a heritage asset, to avoid or minimise any conflict between the heritage asset’s conservation and any aspect of the proposal.”

In addition to the above, the Listing Description notes that the statue of Edward Colston is designated at Grade II for the following principal reasons:

- “A handsome statue, erected in the late C19 to commemorate a late C17 figure; the resulting contrast of styles is handled with confidence
- The statue is of particular historical interest, the subject being Edward Colston, Bristol’s most famous philanthropist, now also noted for his involvement in the slave trade
- Group value with other Bristol memorials: a statue of Edmund Burke, the Cenotaph, and a drinking fountain commemorating the Industrial and Fine Art Exhibition of 1893”

The Conservation comments also refer to Historic England’s guidance regarding significance and heritage values, which includes: evidential value, historic value, aesthetic value, and communal value. This analysis can be read in full above, however they conclude that “whilst the aesthetic value has been significantly impacted, and the traditional historic and evidential values altered, the actual historic significance of the statue and plinth have been increased through the actions of 2020 regardless of its current state.” Insofar as the impacts on the Conservation Area are concerned, the Conservation comments note that the proposal would have the potential to impact the character of the City and Queen Square, and College Green Conservation Areas. In particular the group value of the collection of Listed civic monuments along the Centre would also have their setting impacted.

Historic England have also commented on the significance of the asset. This can also be read in full above, and they have concluded that “the significant of the Colston monument, in the language of the NPPF, lies in its artistic and historic interest, both of which are considerable.”

Also of note are the views of the Inspector in their consideration of the non-determination appeals for the Jen Reid temporary art installation (appeal references APP/Z0116/W/20/3260461 and APP/Z0116/Y/21/3269256), where the Inspector noted that the significance of the asset was artistic and historic.

Taking into account the description of significance provided by the applicant and the available evidence and expertise relevant to this application for listed building consent, it is considered that the Local Planning Authority has sufficient information to identify and assess the particular significance of the heritage asset and to take this into account when considering the impacts. This significance is considered to be principally artistic and historic, with the historic significance of the statue and plinth having been increased.

Assessment and Potential Mitigation

Historic England have advised that legally, the statue of Colston and its plinth remain intact and in situ, and as such this is the correct starting point in planning terms. This is also the approach that the Inspector took in considering the non-determination appeals for the Jen Reid temporary art installation.

Regard must also be had to Paragraph 202 of the NPPF which states “Where there is evidence of deliberate neglect of, or damage to, a heritage asset, the deteriorated state of the heritage asset should not be taken into account in any decision.”

The toppling of the statue from the plinth is considered to be evidence of damage having regard to the wording of the above paragraph, so the deteriorated state cannot be taken into account by the Local Planning Authority in the decision. As Conservation note however, this creates something of a paradox, where a degree of historic significance of the asset may now arise from its effective separation. Whilst the NPPF states that the deteriorated state cannot be taken into account in the decision, Conservation also note it does not appear to preclude that evidence of damage having increased the heritage significance or the assessment of that significance as part of assessing against the tests of the NPPF.

Paragraph 205 of the NPPF states “when considering the impact of a proposed development on the significance of a designated heritage asset, great weight should be given to the asset’s conservation (and the more important the asset, the greater the weight should be). This is irrespective of whether any potential harm amounts to substantial harm, total loss or less than substantial harm to its significance.”

Accordingly, the Local Planning Authority must give great weight to the asset’s conservation when considering the impact of the proposal on the significance of the heritage asset and undertaking the assessment that now follows.

Is there harm posed to the significance of the Listed Building by the works? (Paragraph 206 of the NPPF)

The applicant submits that the harm arising from the proposal would be less than substantial harm.

They have noted in their supporting statement that the NPPF states that where there is evidence of deliberate neglect of, or damage to, a heritage asset, the deteriorated state of the heritage asset should not be taken into account in any decision.

The applicant considers that a high degree of harm to the statue and plinth has already occurred as a result of the events of June 2020. Their view is that the significance of the asset has not been entirely lost and in some aspects, such as historic interest the asset’s significance has increased, as detailed above.

The applicant further advises that the museum has recovered and placed the statue in its stores. A condition survey and conservation work to the statue has taken place as set out in the accompanying documents. The applicant states that the museum’s ‘Collections Care & Preservation Policy and Strategy’ will ensure that no further harm comes to the statue and this care extends to any display of the artefact.

The applicant also acknowledges that the proposed plaque on the plinth will impact on the character and appearance of the grade II listed asset and will cause a level of harm to the asset. The size of the plaque has been kept to the minimum required to neatly cover the

Development Control Committee B – 21 February 2024**Application No. 23/04315/LA : Statue Of Edward Colston Colston Avenue Bristol BS1 4UA**

existing damage to the stonework and the materials have been chosen to complement the aesthetic of the statue and its pedestal.

Having regard to the comments received from Bristol City Council's Conservation team and Historic England, it is clear that there is some difference of view from consultees as to the level of harm to the significance of heritage asset that would occur as a result of the works. Based on the comments received this appears to have arisen in part due to the extent to which the events of June 2020 are considered to have affected the significance of the asset, having regard to the different types of interest described by the NPPF and the Historic England Guidance.

The Council's Conservation team considers that the harm to significance is "not of a substantial degree", and so would be less than substantial harm in the terms of the NPPF. The Council's Conservation team have commented that "certain of the heritage values underpinning significance would be harmed by the proposed development, others sustained and enhanced. Conversely, should development be refused, the heritage values would be harmed in other ways. However, the statue is an integral and key component of the Listed building and its removal is, on balance, considered to cause harm to significance. The proposals to protect the statue in an alternative location and provide interpretation on the standing plinth help mitigate that harm. Overall, therefore, the harm to significance is not of a substantial degree."

On the other hand, Historic England considers that the harm would be substantial harm in the terms of the NPPF. Historic England have commented that "the removal of the statue of Colston from the monument of which it forms part would severely impair the monument's significance. The statue is the *raison d'être* of the monument itself. It represents the man the monument commemorates and is the most artistically important part of the whole. The removal of the statue would take away much of the monument's historic and artistic interest. This notwithstanding, the plinth itself would remain of some interest. It is a substantial structure, carefully composed and richly adorned, and is of historic and artistic interest in its own right."

Of relevance to how harm should be viewed are also the conclusions reached by the Inspector in considering the non-determination appeals for the Jen Reid temporary art installation. The Inspector considered the significance of the designated heritage asset, as noted above, and considered that the proposal under consideration in that case, noting it would be for a temporary period and the heritage value of the plinth itself, would result in harm that would be less than substantial.

Having regard to the application and comments received, officers consider on balance that the works would lead to less than substantial harm to the significance of the designated heritage asset.

Has clear and convincing justification been given for the harm? (NPPF para 206):

Paragraph 206 of the NPPF states that "any harm to, or loss of, the significance of a designated heritage asset (from its alteration or destruction, or from development within its setting), should require clear and convincing justification."

There is considered to be clear and convincing justification for the harm that would occur. The comments from the Council's Conservation team are considered to address this succinctly:

“It's clear in this instance, that the totality of the public benefits could only be achieved through the removal of the statue to a secure public collection. Allowing the statue to remain on the plinth would expose it to further attack, damage and the risk of provoking further civil unrest. It is no longer possible to protect the architectural and historic interest with the statue and base attached to the plinth. Whilst the approach would usually be 'retain and explain' assets of contested heritage, the now-international profile of the statue and broader understanding of Colston's history in slave trading brought about for the 2020 actions, have focussed negative attention on the celebration of Colston, and retention would be enticement to future acts of a similar violent nature.

The current condition of the bronze casting is very poor. Whilst it's damaged state cannot form part of our decision making, the statue itself cannot continue to form part of the Listed asset as a whole. We are satisfied that, due to the irreparable and Insafe condition of the statue, it would require recasting if it were to remain integral to the plinth. Any replacement of the statue would not have the same heritage value as the original Victorian casting, even if the appearance could be replicated. With a facsimile in place of the original, the original integrity could not be fully restored. The replacement would remain provocative, the target of vandalism and antisocial behaviour, and the potential focus of civil unrest. A statue of Colston remaining on the plinth is not a reasonable expectation.”

**Do the public benefits of the proposal outweigh the less than substantial harm?
(Paragraph 208 of the NPPF)**

Where works would lead to less than substantial harm that harm should be weighed against the public benefits of the proposal. Officers consider that less than substantial harm would be caused to the significance of the listed building and also the Conservation Area. Balanced against this the applicant has identified public benefits.

They submit that the public benefits of providing an improved historic contextual balance to the statue and plinth that addresses this sensitive contested heritage issue outweighs this harm.

To summarise the applicant's justification for the proposals, they consider that placing of the statue in the care of the M Shed museum will ensure its long term preservation. This would be accompanied by contextual information and a new plaque on the Colston avenue plinth. The original plaques would remain in place. The applicant has provided some suggested wording for the new plaque, as follows:

“On 13th November 1895, a statue of Edward Colston (1636 - 1721) was unveiled here celebrating him as a city benefactor. In the late twentieth and early twenty-first century, the celebration of Colston was increasingly challenged given his prominent role in the enslavement of African people.

On 7th June 2020, the statue was pulled down during Black Lives Matter protests and rolled into the harbour. Following consultation with the city in 2021, the statue entered the collections of Bristol City Council's museums.”

The applicant proposes that the new plaque would be cast in bronze and measure 600mm wide by 400mm high and fixed to the pedestal using grouting rods set within mortar joints. It should be noted that Listed Building Consent was granted in November 2018 under application reference 18/03688/LA for the addition of a new bronze plaque to the stone pedestal which was of similar dimensions.

Development Control Committee B – 21 February 2024**Application No. 23/04315/LA : Statue Of Edward Colston Colston Avenue Bristol BS1 4UA**

The applicant also submits that “Any reinstatement [of the statue] would cause additional upset and disgust and potentially lead to further public order and health and safety risks as well as damage community cohesion.”

In a Written Ministerial Statement made to Parliament on 18 January 2021, the then Secretary of State for Housing, Communities and Local Government, stated about statues and monuments that “decisions to remove any such heritage assets owned by a local authority should be taken in accordance with its constitution, following consultation with the local community and interested parties, and the rationale for a decision to remove should be transparent.” This Written Ministerial Statement is also a material consideration when deciding applications.

As noted above, the approach for both the statue and plinth is the result of an “extensive city wide consultation” as detailed in ‘The Colston Statue what next?’ History Commission Report, the key results from which have been summarised above.

In their comments on this application, Historic England have noted that the report makes clear that opinion, although broadly in favour of the proposals, is also divided. It is noted that the objections received raise concerns regarding this process in terms of the options presented, but this is considered to be beyond the scope of the assessment of this application.

Historic England however “acknowledge the seriousness with which this exercise has been conducted” and considers that “this approach seems wholly in accordance with the Secretary of State’s requirement that councils consult communities when considering such proposals.” Officers consider that the History Commission’s Report should be given significant weight and that the aims of the Written Ministerial Statement appear to have been met.

Whilst the Council’s Conservation team consider that there would be an overwhelming degree of public benefit associated with the proposal and note specifically that the proposal would minimise the potential for criminal damage and vandalism of the listed structure, and that greater community cohesion would be encouraged and relationships repaired.

They also comment that the statue would form part of a secure accredited museum collection with enhanced conservation requirements, where people have the option to view it should they choose to. The proposals would also provide opportunity for interpreting contested heritage through the retention and contextualisation of the plinth with a new plaque, and the further explanation of the heritage significance as part of museum collections.

They consider that the enhanced interpretation of statue and plinth would have an additional heritage benefit, where the international significance of statue and plinth could be greatly enhanced. They also comment that there would be economic benefits associated with tourism, although it would be difficult to quantify this benefit, along with the costs that may be incurred associated with the damaged condition of the statue.

There is therefore considered to be clear and convincing justification for the harm. This harm would be less than substantial harm and this has harm has been weighed against the public benefits of the proposal as required by Paragraph 208 of the NPPF. Great weight has also been given to the asset’s conservation when considering the impact of the proposal on the significance of the heritage asset.

Development Control Committee B – 21 February 2024**Application No. 23/04315/LA : Statue Of Edward Colston Colston Avenue Bristol BS1 4UA**

Returning to the aims of achieving sustainable development as set out in Section 2 of the NPPF, it is considered that the social objective of supporting communities' health, social and cultural well-being would be central to the public benefits that would be achieved. Environmental objectives would also be met of protecting and enhancing our built and historic environment.

Paragraph 204 of the NPPF states "In considering any applications to remove or alter a historic statue, plaque, memorial or monument (whether listed or not), local planning authorities should have regard to the importance of their retention in situ and, where appropriate, of explaining their historic and social context rather than removal." This can be summarised as 'retain and explain'. The Local Planning authority must have regard to the importance of this in determining this application.

Whilst the applicant submits that this will address the 'retain and explain' requirements of this paragraph of the NPPF, it is considered that the proposal would conflict with this paragraph, as the statue would be moved from the plinth and put on display in the M Shed museum with accompanying contextual information however combined with a proposed new plaque on the plinth. Whilst the applicant has set out some suggested wording for this, which it is expected would be confirmed outside of the planning process, it is recommended that the final details are to be secured by condition to ensure these can be considered.

Regard has been had to the importance of the retention of the statue in situ together with the plinth, however when also considering the great weight required in the conservation of designated heritage assets and the substantial public benefits mentioned above, it is considered that the addition of a new permanent plaque installed on the plinth is appropriate in the circumstances in terms of contextualising the empty plinth the fallen statue, noting other the public benefits associated with the proposal.

Assessment to be undertaken if the proposal is considered to constitute Substantial Harm

Should the Committee be of the view that the harm to the heritage asset would be substantial harm in the terms of the NPPF, Paragraph 207 would apply. This states the following:

"Where a proposed development will lead to substantial harm to (or total loss of significance of) a designated heritage asset, local planning authorities should refuse consent, unless it can be demonstrated that the substantial harm or total loss is necessary to achieve substantial public benefits that outweigh that harm or loss, or all of the following apply:

- (a) the nature of the heritage asset prevents all reasonable uses of the site; and
- (b) no viable use of the heritage asset itself can be found in the medium term through appropriate marketing that will enable its conservation; and
- (c) conservation by grant-funding or some form of not for profit, charitable or public ownership is demonstrably not possible; and
- (d) the harm or loss is outweighed by the benefit of bringing the site back into use."

It is important to note that this test requires consideration to be given as to whether the substantial harm is necessary to achieve substantial public benefits that outweigh that harm.

Conclusion

It is therefore concluded that the public benefits would outweigh the less than substantial harm posed. In reaching this conclusion, officers have given great weight to the heritage asset's conservation, that is, the sustaining and enhancing of its significance.

The public benefits are considered to outweigh the less than substantial harm. There is clear and convincing justification for the harm.

The proposal is therefore considered to be in accordance with the requirements of the NPPF, Bristol Core Strategy (2011) Policy BCS22 which seeks to ensure that development proposals safeguard or enhance heritage assets in the city, with Policy DM31 in the Site Allocations and Development Management Policies (2014) expressing that alterations to buildings should preserve or enhance historic settings.

The statutory provisions of Section 16 of the Planning (Listed Buildings and Conservation Areas) Act 1990, which states that in considering whether to grant listed building consent for any works the local planning authority shall have special regard to the desirability of preserving the building or its setting or any features of special architectural or historic interest which it possesses. Have also been taken into account and are considered to have been complied with.

Returning to the general duty to under Section 72 of the Planning (Listed Buildings and Conservation Areas) Act 1990 which relates to duty in respect of conservation areas when exercising planning functions, special attention has also been paid to the desirability of preserving or enhancing the character or appearance of that area and the public benefits would outweigh the less than substantial harm posed.

It is therefore recommended that Listed Building Consent be granted. Conditions are recommended regarding the implementation of the proposed works.

RECOMMENDATION

Grant Subject to Conditions

1) The development hereby permitted shall begin before the expiration of three years from the date of this permission.

Reason: As required by Section 18 of the Planning (Listed Buildings and Conservation Areas) Act 1990, as amended by Section 51 of the Planning and Compulsory Act 2004.

2) Prior to installation of the plaque, the following detailed drawings shall be submitted to the Local Authority and approved in writing:

- a) 1:5 section and elevation drawings of the proposed plaque showing it's intended materials, profiles, design, fixings, typeface, and wording
- b) 1:10 elevation detail of the plinth showing the location of the proposed plaque and its fixings

The plaque shall be installed no later than 12 months from the date of the statue and base going on display as part of the Bristol Museums collections, unless otherwise agreed in writing with the Local Planning Authority.

Development Control Committee B – 21 February 2024

Application No. 23/04315/LA : Statue Of Edward Colston Colston Avenue Bristol BS1 4UA

Reason: To safeguard the architectural and historic interest of the Listed structure and the special character of the Conservation Area and to ensure the public benefits of development are secured in their totality.

3) Prior to completion of the works, written confirmation must be provided to the Local Authority that the statue and statue base have been formally entered as accessioned artefacts in the Bristol Museums collection. The statue and base shall be retained as accessioned artefacts unless otherwise agreed in writing with the Local Planning Authority.

Reason: To ensure the public benefits of development are secured in their totality.

4) Prior to the completion of the works, a management plan for the display and interpretation of the statue and statue base as part of Bristol Museums collections should be submitted to the Local Authority and approved in writing. Once approved, the management plan should be fully implemented unless otherwise agreed.

Reason: To ensure the public benefits of development are secured in their totality.

5) List of approved plans and drawings

The development shall conform in all aspects with the plans and details shown in the application as listed below, unless variations are agreed by the Local Planning Authority in order to discharge other conditions attached to this decision.

Colston Statue Location Plan, received 7th November 2023

M Shed Location Plan, received 7th November 2023

Heritage and Design Statement, May 2023, received 7th November 2023

Bristol Museums & Art Gallery Condition Report, received 7th November 2023

Bristol Culture Collection Care and Preservation Policy & Strategy 2017-2022, received 8th February 2024

Colston Statue Treatment Report, received 8th February 2024

Supporting Documents

1. Statue of Edward Colston, Colston Avenue

1. Colston Avenue Location Plan
2. M Shed Location Plan
3. Heritage and Design Statement
4. Bristol History Commission Report The Colston Statue What Next?
5. Colston Statue Condition Report
6. Colston Statue Treatment Report
7. Bristol Culture Collection Care and Preservation Policy & Strategy
8. Equality Impact Assessment



Colston Statue, Implementing the We Are Bristol History Commission's Recommendations



Contents

1 Introduction **Page no 4**

1.1 Background

1.2 Planning policy context

2 Historic significance **Page no 6**

2.1 Edward Colston

2.2 The statue

2.3 Significance following 7th June 2020

3 The recommendations **Page no 10**

3.1 The Statue of Edward Colston (1-3)

3.2 The empty plinth (4)

3.3 Assessment of harm

3.4 Statement of community involvement

3.5 Conclusion

Appendices

History_Commission_Short_Report_Final.pdf

Colston Condition Report Oct 2020.pdf

Colston statue treatment report Oct 2020.pdf

Bristol Culture Collections Care & Preservation
Policy and Strategy 17-22.pdf

1 Introduction

1.1 Background

In 2023, Bristol City Council will be applying for listed building consent to implement certain recommendations for the future of the Colston statue and empty plinth as proposed by the History Commission.

On 7th June 2020, the grade II listed bronze statue of Edward Colston was pulled down from its plinth on Colston Avenue during a Black Lives Matter demonstration. After being rolled through the City Centre, the statue was dumped into the Floating Harbour by a crowd of demonstrators.

The statue was recovered from the harbour and in the summer of 2021 went on display in the M Shed museum. While on display, Bristol City Council and the History Commission that had been established by the authority following the events in June, ran a public consultation process with visitors to the exhibition and online. This consultation asked what people thought should now happen to the statue and surviving plinth in the City Centre. The results of this consultation process informed a report by the commission that concluded with 6 recommendations for the future of the statue and plinth.

Of the six recommendations (see below, section 3), 1-3 concerning the statue will require listed building consent to fulfil. Recommendation 4 concerning the empty plinth proposes that a new plaque is installed. There is an existing consent for a plaque (18/03688/LA) and it is the intention to include the installation of a plaque with the Commission's proposed wording as part of this forthcoming application.

1.2 Planning policy context

Despite the events of June 2020, the statue of Edward Colston, now stored in the M Shed museum, remains a grade II listed heritage asset along with the surviving plinth on Colston Avenue. Consequently, any works to the statue and plinth will require listed building consent in accordance with the Planning (Listed Buildings and Conservation Areas) Act 1990.

Other relevant planning policies and guidance include:

- National Planning Policy Framework (NPPF), Section 12
- Bristol Local Plan, policies BCS22 and DM31

In accordance with paragraphs 194, 198 and 200-202 of the NPPF this document:

- Provides a statement of significance for the statue and plinth in their current state
- Details how the Council proposes to retain and explain the asset's story
- Includes an assessment of any harm that delivering the recommendations pose for the significance of the asset
- Provides clear and convincing justification for any potential harm
- Sets out public benefits that will result from the Council's proposal

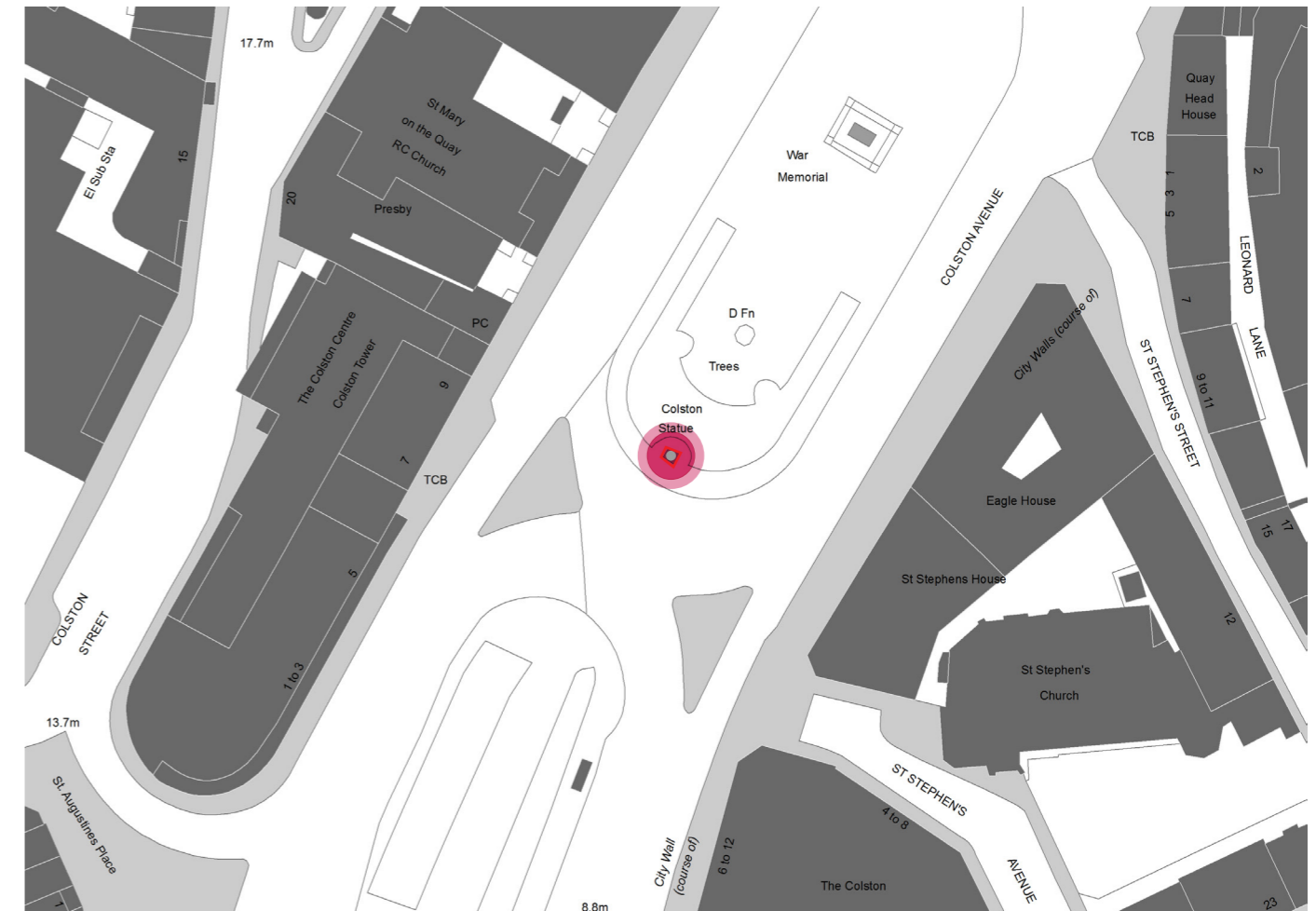

Plan showing the location of the plinth

Not to scale

2 Historic significance

2.1 Edward Colston

Edward Colston was born in 1636 within the Temple area of Bristol. He was the son of a wealthy merchant and became a member of the Society of Merchant Venturers, an alderman of Bristol and later in life represented the city as a Tory MP in Parliament, although he lived most of his life in London, dying in Mortlake in 1721.

He gave enormous sums from his wealth to charitable causes establishing Colston's Almshouse on St Michael's Hill in 1691 and founding the Colston's Hospital boys school in 1710.

Despite this benevolence Colston was selective about who could receive the benefits of his charity restricting beneficiaries to those from similar religious (Anglican) and political (Tory) backgrounds.

There is little doubt about the source of the majority of Colston's wealth. As an investor in the sugar trade Colston will have directly contributed from profits derived from the production of slave produced goods and as a member of the Royal African Company his connection with the enslavement of Africans is even more explicit.

2.2 The statue

Following the creation of a fixed bridge, St Augustine's Bridge to replace the earlier Drawbridge in 1890, the northern end of the Floating Harbour became inaccessible to shipping. Consequently between 1892 and 1893 the River Frome was culverted from the Stone Bridge at the Quay Head, near to the present Electricity House, and St Augustine's Bridge close to the end of Clare Street.

The space that resulted from this work was used as a venue for the temporary Bristol Industrial and Fine Art Exhibition in 1893 before becoming Magpie Park.

After the exhibition there were proposals for commemorative statues to be erected in the new park. The first of these was a statue of Edmund Burke, former Whig MP for Bristol, by the sculptor James Haverd Thomas. This sculpture was a gift to the city from William Henry Wills and was erected in 1894.

At the same time as the statue of Burke was being proposed and designed there were calls, mainly from the printer J.W. Arrowsmith, for a statue of Colston to be added to the park. Fund raising for this statue had limited success and it is generally believed that the costs were covered by Arrowsmith himself.

The bronze statue was created by John Cassidy and erected in 1895. It was cast at Coalbrookdale and is consequently one of the last examples of this connection, Abraham Darby the founder of the Coalbrookdale works and Thomas Goldney a key investor in the company both being Bristolians.

The grade II listed bronze statue stood on a Hopton Wood stone pedestal with further bronze plaques and bronze figurative 'dolphins' fixed to the four sides and corners of the pedestal.

Dimensions:

Statue - 2.6m high with 800mm square base

Stone pedestal - 3.15m high

Four relief plaques - 950mm high, 650mm wide

The principle relief plaque states:

"ERECTED : BY : / CITIZENS OF
BRISTOL / AS A MEMORIAL / OF
ONE OF THE MOST / VIRTUOUS :
AND / WISE : SONS OF / THEIR :
CITY / A.D. 1895"



Statue of Edward Colston, c.1900

2.3 Significance following 7th June 2020

The actions in June 2020 has caused a high degree of harm to the asset's significance. The direct connection between the statue and the plinth as well as the statue's setting within the College Green Conservation Area adjacent to several other designated monuments has obviously now been lost.

However, the events of 7th June 2020 reached a global audience bringing international recognition to Bristol, Edward Colston, contested heritage in general and wider injustices.

The now fallen statue and empty plinth are monuments to an international story about enslavement, misguided Victorian commemoration, and modern reactions to injustice.

However, the historic significance of both statue and plinth has now arguably increased. They will always be connected with the moment the statue commemorating a man who had direct connections with the enslavement, torture and death of thousands of people was torn down by demonstrators.

In the weeks and months since, the plinth and surrounding public realm has become a dynamic space, being the focus of conversations and interventions such as the Jen Reid statue and other temporary pieces.



Above and left, photographs of the plinth taken 8th June, 2020

3 The recommendations

3.1 The Statue of Edward Colston

The first three recommendations relate to the future of the statue currently stored at M Shed. Attached to this pre-application are three supporting documents produced by the museum:

- Colston Condition Report Oct 2020
- Colston statue treatment report Oct 2020
- Bristol Culture Collections Care & Preservation Policy and Strategy 17-22

Recommendation 1

That the Colston statue enters the permanent collection of the Bristol City Council Museums Service.

Recommendation 2

That the statue is preserved in its current state and the opportunity to reflect this in the listing description is explored with Historic England.

Recommendation 3

That the statue be exhibited, drawing on the principles and practice of the temporary M Shed display where the statue was lying horizontally. That attention is paid to presenting the history in a nuanced, contextualised and engaging way, including information on the broader history of the enslavement of people of African descent.



The face of the statue following the events of June 2020

3.2 The empty plinth

Recommendation 4

That the former Colston statue plinth, along with the original plaques, remain in place and that a new plaque is installed that briefly and factually explains when and why the statue was put up and taken down.

The following wording for the new plaque is suggested:

On 13th November 1895, a statue of Edward Colston (1636 - 1721) was unveiled here celebrating him as a city benefactor. In the late twentieth and early twenty-first century, the celebration of Colston was increasingly challenged given his prominent role in the enslavement of African people.

On 7th June 2020, the statue was pulled down during Black Lives Matter protests and rolled into the harbour. Following consultation with the city in 2021, the statue entered the collections of Bristol City Council's museums.

Design Specification from consented listed building application 18/03688/LA

The plaque will be cast in bronze and measure 600mm wide by 400mm high and fixed to the pedestal using grouting rods set within mortar joints as shown.

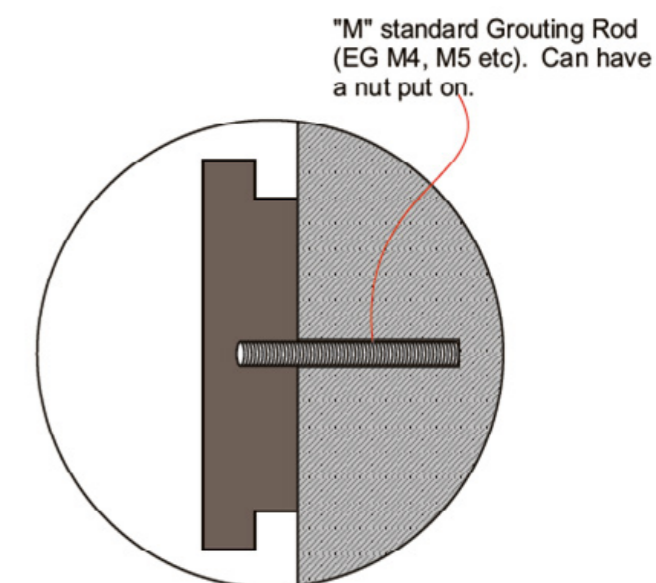

Mortar joints on pedestal

3.3 Assessment of harm

Paragraph 196 of the NPPF states that where there is evidence of deliberate neglect of, or damage to, a heritage asset, the deteriorated state of the heritage asset should not be taken into account in any decision.

The high degree of harm to the statue and plinth has already occurred as a result of the events of June 2020. Our view is that the significance of the asset has not been entirely lost and in some aspects, such as historic interest the asset's significance has increased as detailed above (section 2.3).

The museum has recovered and placed the statue in its stores. A condition survey and conservation work to the statue has taken place as set out in the accompanying documents.

The museum's 'Collections Care & Preservation Policy and Strategy' will ensure that no further harm comes to the statue and this care extends to any display of the artefact.

As the proposed plaque on the plinth will impact on the character and appearance of this grade II listed asset it will cause a level of harm to the asset.

The size of the plaque has been kept to the minimum required to neatly cover the existing damage to the stonework and the materials have been chosen to complement the aesthetic of the statue and its pedestal.

Consequently we have assessed this harm to be a high degree of less than substantial and feel that the public benefits of providing an improved historic contextual balance to the statue and plinth that addresses this sensitive contested heritage issue outweighs this harm.

3.4 Statement of community involvement

The History Commission's recommendations are the result of an extensive city wide consultation process as detailed in the accompanying 'The Colston Statue what next?' report.

The key results from this consultation relevant to this application were that:

- 80% of respondents agreed that the statue should be displayed in a museum
- 70% agreed that a new plaque should be added to the plinth
- 14,000 people responded to the consultation from a good representative sample of the city population, over 50% of whom were from BS postcodes (History Commission short report pages 10-15)

Should the Colston statue be on display in a museum in Bristol?

“ It should be in a museum. Statues are celebratory, museums are educational.

“ I'd like to know more about how much of the city's architecture came from money, directly or indirectly, due to the triangular trade.

“ Display it in a way that encourages reflection on Bristol's past and the ripples of that past in the present, not reverence.

“ It's not 'rewriting history' to remove a statue if it's preserved in a museum in an appropriate context.

“ It should be cleaned up and restored to its rightful place on the plinth.

Extract from the History Commission report

3.5 Conclusion

“Historic England’s approach to contested heritage, to which the Written Ministerial Statement refers, is to advocate the retention and conservation of such heritage, coupled with the provision of powerful and long-lasting interpretation that tells the full story of the monument or building concerned.

Historic England has already stated publicly that we recognise that other considerations might outweigh those in favour of reinstating Colston’s statue, even if accompanied by reinterpretation which is both powerful and long-lasting,”

‘A Surge of Power (Jen Reid)’ appeal statement on behalf of Historic England by John Neale, Head of Development Advice, paragraph 1.26.

The statue of Edward Colston, a man with direct connections to the trans-Atlantic trafficking of enslaved people in the late 17th and early 18th century, was and remains an affront to many of Bristol’s citizens.

Consequently, the forthcoming listed building application will not consider the reinstatement of the statue to Edward Colston. Any reinstatement would cause additional upset and disgust and potentially lead to further public order and health and safety risks as well as damage community cohesion.

The forthcoming listed building application by the City Council will propose that placing the statue in the care of the museum will ensure it’s long term preservation.

Putting the statue on display in the M Shed museum with accompanying contextual information combined with a proposed new plaque on the Colston Avenue plinth will address the ‘retain and explain’ requirements of paragraph 198 of the NPPF.

The approach for both the statue and plinth as set out by the application is the result of an extensive city wide consultation as detailed in ‘The Colston Statue what next?’ History Commission Report.

The two remaining recommendations concerning amending the College Green Conservation Area Character Appraisal to reflect the events of June 2020 (recommendation 5) and a cultural programme for the site of the plinth (recommendation 6) will not be the subject of any forthcoming listed building application.

The Colston Statue

What Next?



With thanks to all those at Bristol City Council who contributed to all aspects of the display and engagement, in particular to Ray Barnett, Amber Druce, Simon Fenn, Jon Finch, Fiona Gilmour, Lisa Graves, Gail Kendell, Lauren MacCarthy, Laura Martin, Barry Norris, Becky Peters, Fiona Russell, Jon Severs and Finn White. Thanks also to colleagues in Design, Conservation & Documentation, External Communications, Consultation & Engagement, Participation & Communities, Neighbourhood Engagement, Digital, City Design, and the M Shed Front of House teams and Curatorial colleagues.

Short Report Authors: Joanna Burch-Brown (University of Bristol and Co-Chair of 'We Are Bristol' History Commission) and Tim Cole (University of Bristol and Chair of 'We are Bristol' History Commission), with Edson Burton, Nigel Costley, Steve Poole, Shawn Sobers and Estella Tincknell.

Design: Shirine Watts (University of Bristol Design Team, Print Services)

Research: Jon Toy and Lauren Maddox (Bristol City Council Consultation & Engagement), Tim Cole and Ana-Maria Cretu (University of Bristol)

Copy editing: Rob Mitchell (University of Bristol Print Services)

Photos: Cover & p6 Khali Ackford; p7 Jo Norman; p11 LucyOn / Shutterstock.com; p13 Adrian Sherratt / Alamy Stock; p17, p.23 Carol Burch-Brown; p20 JMF News / Alamy Stock Photo; p24 Joyce Nelson / Shutterstock.com; Inside back cover Bristol and Bath snapper / Alamy Stock Photo

Cite as: Burch-Brown, J & Cole, T et al. 2022. *The Colston Statue: What next? We Are Bristol History Commission Short Report*. Bridging Histories: Bristol

Thanks to University of Bristol and UWE Bristol for funding this report.

In the summer of 2021, the 'We Are Bristol' History Commission opened a public engagement about the future of the Colston statue and the plinth. Nearly 14,000 people joined in to share their ideas and views.

Participants had a chance to see the statue and learn about its history in a display at the M Shed museum. People also viewed the display online. Alongside the display was a survey that invited people from Bristol and beyond to share their views.

We have seen this survey as a chance for the city to speak and for people to listen to each other. This report summarises findings from this historic engagement. We are very grateful to all who took the time to participate, and in due course the millions of words people shared will be available in the city archives in an anonymised format, for anyone to read. The answers you have given will help to decide the future of the statue and plinth.

THE SURVEY QUESTIONS

1. Do you agree or disagree that the Colston statue should be put on display in a museum in Bristol? If you don't agree that the statue should be in a museum, please tell us what you think should happen to it instead? If you agree that the statue should be in a museum permanently, please tell us how you would like to see it displayed.

2. What should be in the plinth space?¹

- Update the plaque on the plinth to reflect the events of 7 June 2020.
- Use the plinth for temporary artworks / sculptures.
- Use the plinth for a permanent artwork / sculpture.
- Keep the plinth but leave it empty.
- If 'other', please specify.

3. How do you feel about the statue being pulled down?² Please tell us why you feel this way.

1 People were asked to say how strongly they agreed with each option: Strongly agree; agree; neither agree nor disagree; disagree; strongly disagree.

2 People selected from these options: I feel very positive; I feel quite positive; I feel neither positive nor negative; I feel quite negative; I feel very negative.

Amongst Bristol respondents, people of key social groups participated in numbers broadly representative of the general population.

Who created the survey?

The survey was a collaboration between the Bristol History Commission, Bristol City Council Consultation and Engagement, and the Bristol Museum and Art Gallery.

What were the aims of the survey?

- ▶ To give everybody a voice
- ▶ To help people learn about each other's views
- ▶ To help make it easy for elected officials to decide next steps for the statue and plinth

What were the values behind the survey?

- ▶ Fairness
- ▶ Inclusive participation
- ▶ Transparency
- ▶ Evidence-based decision making

Who joined in?

Nearly 14,000 people completed the survey (13,984). Of these, just over half were from Bristol City Council area (55 per cent). The Bristol participants were a largely representative cross-section of the city. Amongst Bristol respondents, people of different neighbourhood deprivation levels, ability, and sex participated in numbers broadly representative of the general population. There was some variation in participation along lines of age and ethnicity, with slight under-representation of people 24 and below, and slight under-representation of people identifying as Black or Asian. Every geographical area of the city was well represented: roughly 100 to 200 people per 10,000 residents filled in the survey from almost all of Bristol's 34 wards. People joined in equally from less well-off and more well-off neighbourhoods.

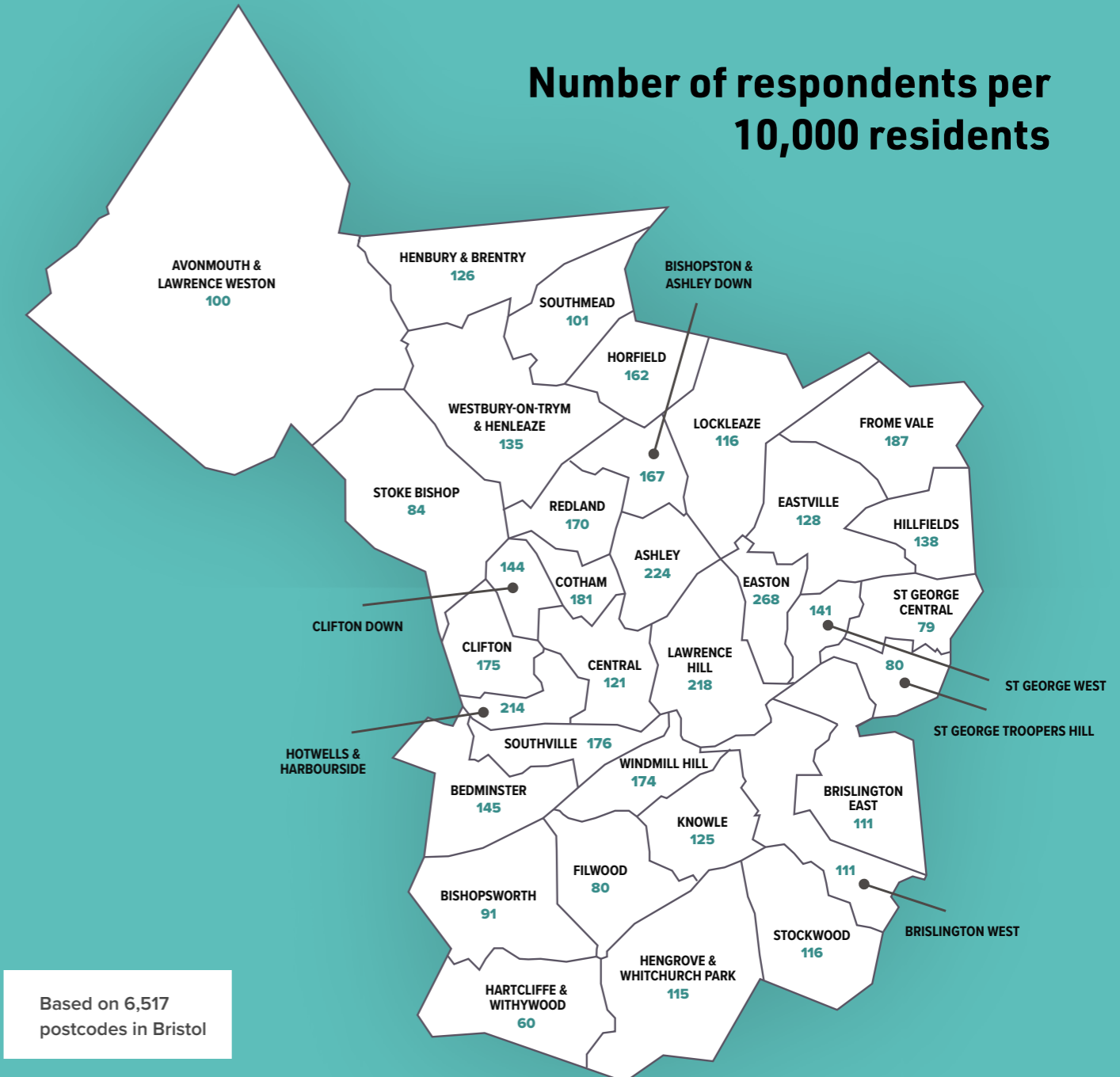

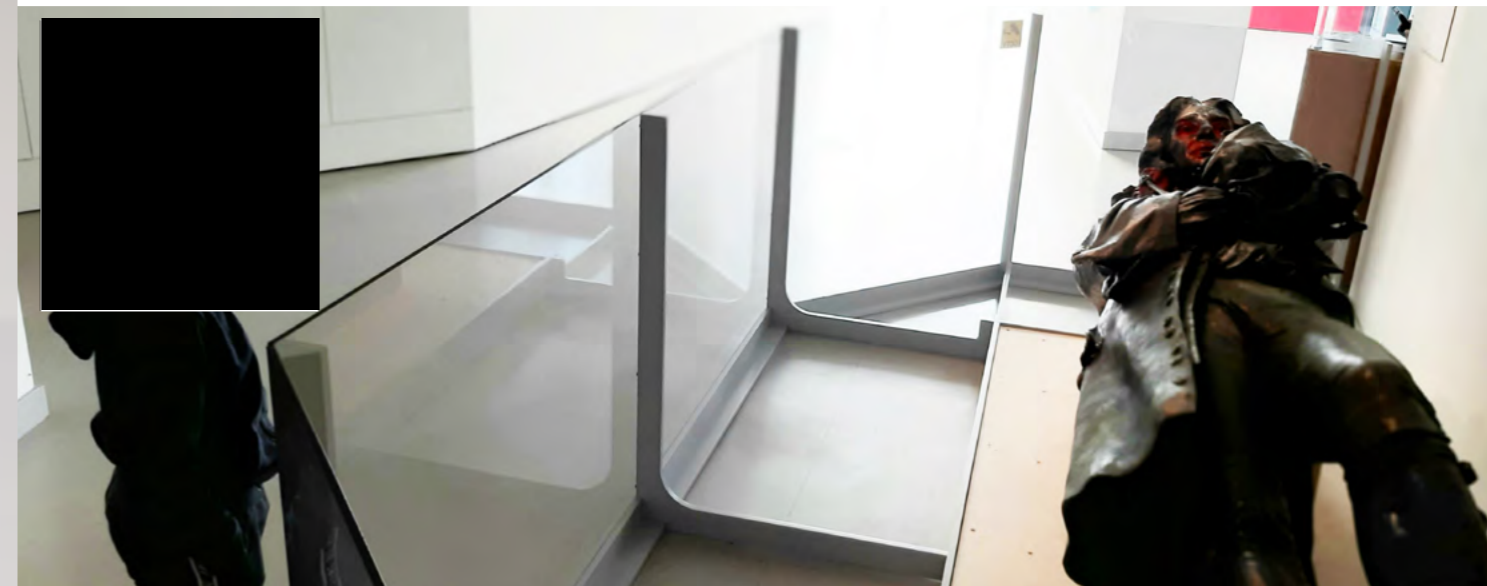

How did you make sure you heard every Bristol neighbourhood fairly?

A few neighbourhoods had lower response rates, so we distributed paper questionnaires and did extra outreach in neighbourhoods with lower initial response rates. We held 16 events at schools including City of Bristol College, Badminton School, Orchard School, City Academy and Bristol Brunel Academy. We held live events for residents of neighbourhoods with lower initial participation: two tours of M Shed with community leaders, and road shows in Fishponds High Street, St Paul's Learning Centre, Ridingleaze in Lawrence Weston, Oldbury Court and Lawrence Hill Urban Park.

For multiple choice questions, we included every response in our results. We then gave equitable voice to each area of the city when analysing the free-text comments people had written.³ This helped us to be confident that we were hearing from all parts of the city.

What will happen next?

Our findings and recommendations are being shared with the Bristol Mayor and elected officials, to help them decide on next steps.

³ With each multiple choice question, there was space for people to add free-text comments. Because there were 14,000 surveys, we could not analyse every comment in detail. Instead we chose a random sample of responses from 2,798 people, from across all Bristol wards. We took the same proportion of comments from each ward, to ensure that people from every area of the city had their voices heard.

WHAT DO PEOPLE WANT?



4 OUT OF 5
Bristol residents think the statue should be displayed in a Bristol museum



7 OUT OF 10
Bristol residents are in favour of adding a plaque to the plinth to reflect events of 7 June 2020



6 OUT OF 10
Bristol residents agree with using the plinth for temporary artworks or sculptures



5 OUT OF 8
Bristol residents said they feel positive about the statue being pulled down

1. Most people wish to see the Colston statue on display in a Bristol museum.

3 out of 4 people said to put the statue in a Bristol museum (74 per cent).

Bristol residents agreed with this option even more strongly, with **4 out of 5 people from Bristol saying the statue should be on display in a Bristol museum (80 per cent)**.

Around 1 in 6 people from Bristol (16 per cent) did not want the statue on display in a Bristol museum. Of this 16 per cent, around three-quarters wanted it returned to the plinth and around one quarter wanted it destroyed or not on display.

4% of Bristol respondents did not have a strong opinion on the matter.

In our sample, for every 1 person from Bristol who said they would like the statue displayed vertically and cleaned up, 5 said to present it in its current state. The most common view was that it should be horizontal and with graffiti intact. Many people said they liked how it appeared in the temporary display.

2. A majority of people support adding a plaque in the vicinity of the plinth to reflect the events of 7 June 2020.

More than 5 out of 8 people (65 per cent) support adding a plaque. Around 3 out of 10 people (29 per cent) disagree with adding a plaque. **Support for a plaque is even stronger in Bristol, where 7 out of 10 Bristol residents (71 per cent) agree with adding a plaque to reflect the events of 7 June 2020.**

3. Nearly 6 out of 10 Bristol respondents (58 per cent) support using the plinth for temporary artworks or sculptures, and another 15% neither agreed nor disagreed, suggesting a total of 7 out of 10 are open to this option (72 per cent).

Opinion was mixed on what to do with the plinth, but a clear majority either support or are open to using the plinth for temporary artworks. Across the survey as a whole, nearly 5 in 8 either agreed with (49 per cent) or neither agreed nor disagreed (15 per cent) with using the plinth in this way. Fewer people were in favour of using the plinth for a permanent artwork (supported by fewer than 4 out of 10) or leaving the plinth empty (supported by 3 out of 10). Smaller numbers wished to see the Colston statue put back up on the plinth (supported by 1 in 10 in the city) or for the plinth to be removed entirely.

4. More than 5 out of 8 Bristol residents (65 per cent) said they feel either very positive (50 per cent) or positive (15 per cent) about the statue being pulled down.

Across the survey as a whole, over half (56 per cent) said they feel positive about the statue being pulled down. Just over 1 in 3 people (36 per cent) reported feeling negative about this, with the manner of removal the number one explanation for feeling this way.

HOW DO DIFFERENT GROUPS FEEL ABOUT THE STATUE COMING DOWN?



Attitudes by ethnicity

Broadly speaking, people from different ethnic groups felt similarly about the statue coming down, and gave similar reasons for their feelings.⁴

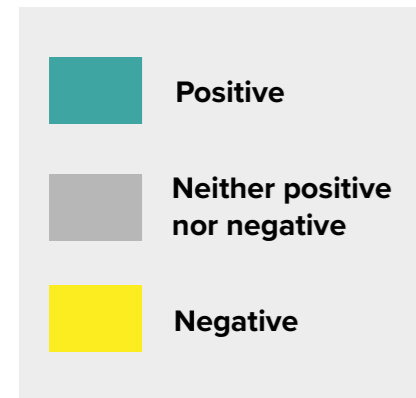

FOR EVERY 20 MIXED ETHNICITY / MULTIPLE HERITAGE Bristol residents, 15 felt positively, 1/2 felt neither positively nor negatively, and 3 1/2 felt negatively



FOR EVERY 20 WHITE BRITISH Bristol residents, 13 said they felt positively, 2 felt neither positively nor negatively, and 5 felt negatively.



FOR EVERY 20 ASIAN / ASIAN BRITISH Bristol residents, 12 1/2 felt positively, 3 1/4 felt neither positively nor negatively, and 4 1/4 felt negatively.



FOR EVERY 20 BLACK / AFRICAN / CARIBBEAN / BLACK BRITISH Bristol residents, 12 felt positively, 2 felt neither positively nor negatively and 6 felt negatively.

⁴ Based on 6152 Bristol residents who reported ethnicity and stated how they feel about the statue being pulled down. Respondents answered on a Likert scale: very positive, positive, neither positive nor negative, negative or very negative. Results simplified here into positive, neither, or negative.

Attitudes by age

Age appeared to make the biggest difference in how people felt about the statue being pulled down.⁵ Younger people reported more positive feelings about the statue coming down.

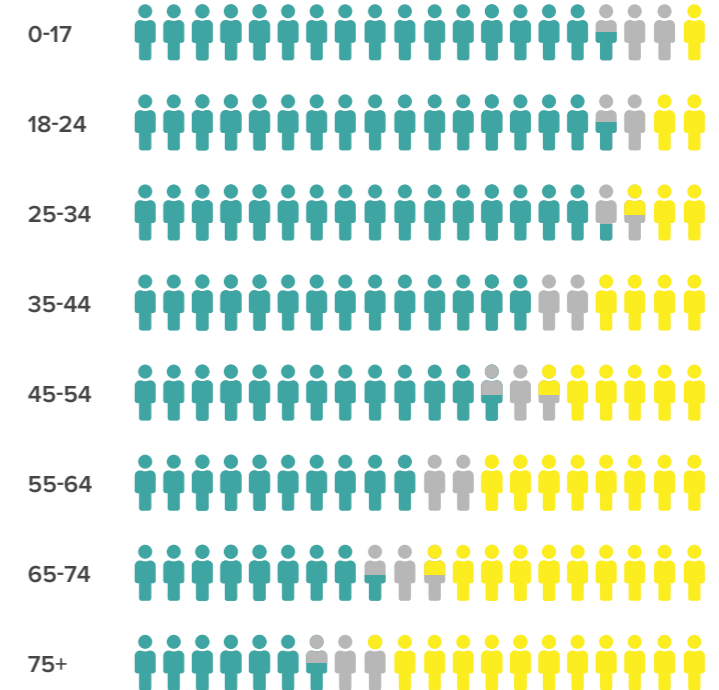

⁵ Based on 6489 Bristol residents who reported age and stated how they feel about the statue being pulled down.

Attitudes by neighbourhood

People felt similarly about the statue coming down, whether they were from more well-off neighbourhoods or less well-off neighbourhoods.⁶

Page 75

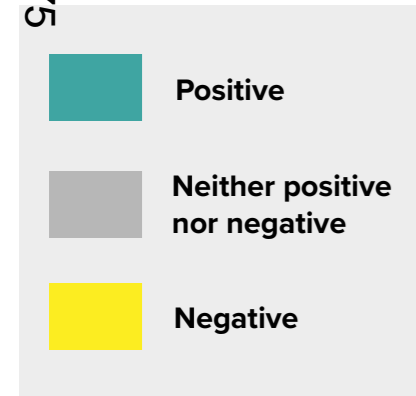

⁶ Based on 6466 residents who provided full postcodes in Bristol and stated how they feel about the statue being pulled down. These figures were arrived at by looking at full postcodes and neighbourhood deprivation levels, using indices of multiple deprivation.

Attitudes by sex

The survey showed some variation in attitudes by sex. 13 out of 20 female respondents felt positively, with similar feelings amongst people identifying as other, whereas 10 in 20 male respondents felt positively.⁷

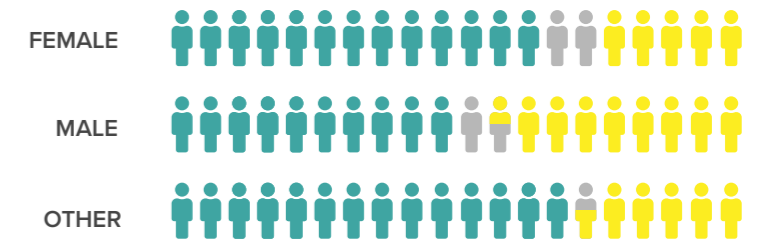

⁷ Based on 12312 respondents from all locations who stated their sex and stated how they feel about the statue being pulled down.

Reasons for positive feelings about the statue coming down

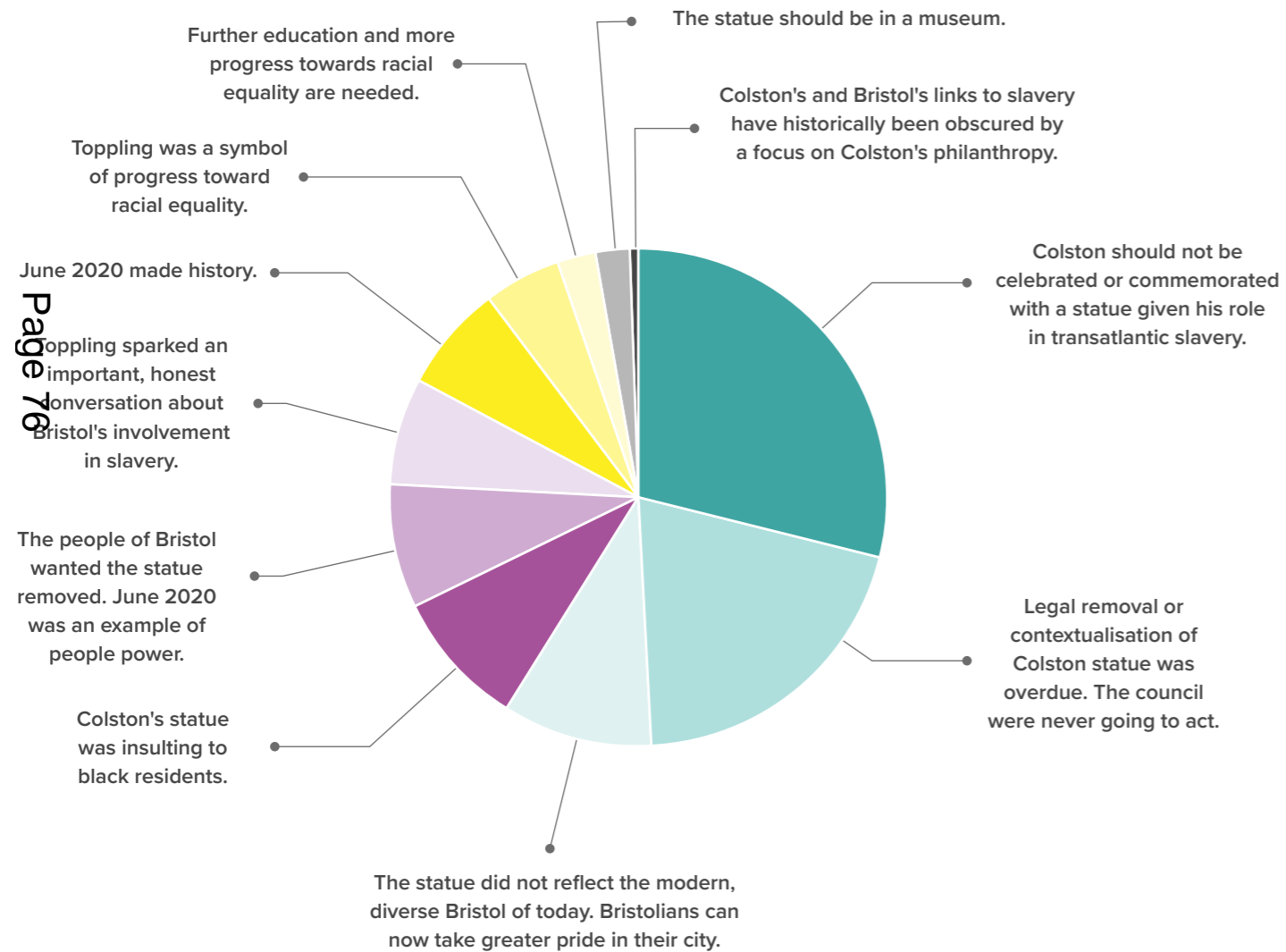

Reasons for negative feelings about the statue coming down

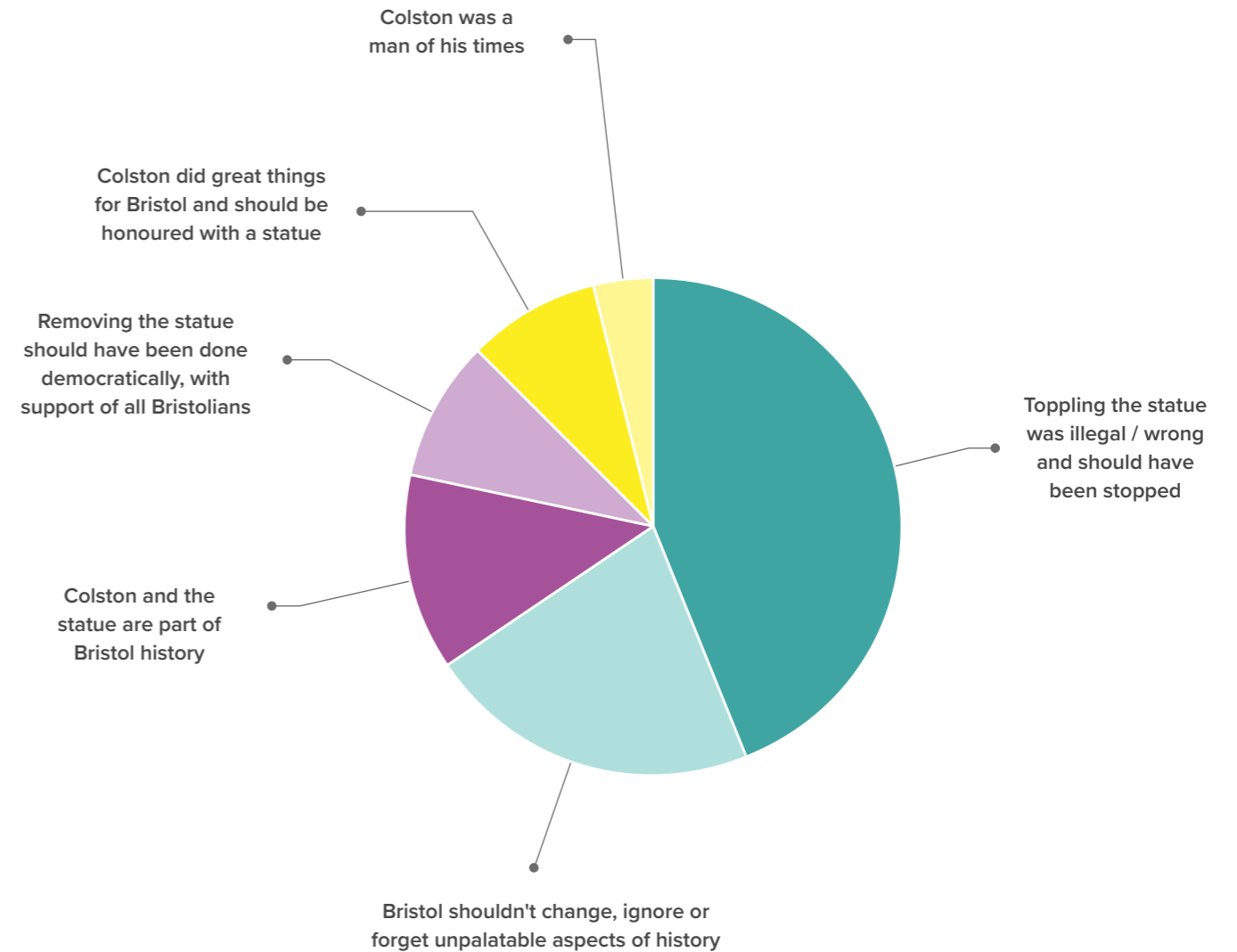

RECOMMENDATIONS

FUTURE OF THE COLSTON STATUE

Recommendation 1

We recommend that the Colston statue enters the permanent collection of the Bristol City Council Museums service.

Recommendation 2

We recommend that the statue is preserved in its current state and the opportunity to reflect this in the listing description is explored with Historic England.

Recommendation 3

We recommend that the statue be exhibited, drawing on the principles and practice of the temporary M Shed display where the statue was lying horizontally. We recommend that attention is paid to presenting the history in a nuanced, contextualised and engaging way, including information on the broader history of the enslavement of people of African descent.



FUTURE OF THE EMPTY PLINTH

Recommendation 4

We recommend that the former Colston statue plinth, along with the original plaques, remain in place and that a new plaque is installed that briefly and factually explains when and why the statue was put up and taken down. We suggest the following wording for the new plaque:

'On 13 November 1895, a statue of Edward Colston (1636 - 1721) was unveiled here celebrating him as a city benefactor. In the late twentieth and early twenty-first century, the celebration of Colston was increasingly challenged given his prominent role in the enslavement of African people. On 7 June 2020, the statue was pulled down during Black Lives Matter protests and rolled into the harbour. Following consultation with the city in 2021, the statue entered the collections of Bristol City Council's museums.'

Page 78

Recommendation 5

We recommend that the Conservation Area Character Appraisal is updated to include a) the events of 7 June 2020, b) this process of public engagement and c) the decision to locate the statue within Bristol City Council Museums service. We recommend that the opportunity to reflect the current state of the plinth in the National List description is explored.

Recommendation 6

We recommend that the city think creatively about the empty plinth and its immediate vicinity. We recommend that funding is sought from public and private sources to commission temporary artworks and activities. These might take a digital or physical form, on and around the plinth. We recommend that two principles guide future use of the plinth:

- that there are periods of intentional emptiness and presence;
- that this is a space for dialogue and conversation about things that matter in and for the city, including the legacy of transatlantic slavery.

BROADER ISSUES EMERGING FROM THE CONSULTATION

- ▶ We see the need for a city-wide commitment to creating opportunities for younger and older generations to interact, share experiences and perspectives and develop greater empathy and mutual understanding, including sharing views on the city's past, present and future.
- ▶ We see the need to develop processes and practices, both locally and nationally, that encourage active engagement in creating more representative public space. When making decisions around contested heritage, public bodies should develop and follow processes that are fair and transparent, inclusive, participatory, evidence-based and committed to justice.⁸
- ▶ The history of the city's involvement with the transatlantic enslavement of African people is not an issue that can or should be consigned to the past, but rather remains embedded in present-day concerns. Strong feelings remain on this topic, and the toppling of the Colston statue has opened the opportunity for the history to be addressed urgently, appropriately and sensitively. We recognise the leadership of the Legacy Steering Group on the question of how Bristol might best memorialise and respond to the transatlantic trafficking and enslavement of African people.⁹

⁸ Further guidance on possible processes can be found at Ben Stephenson, Marie-Annick Gournet and Joanna Burch-Brown, 'Reviewing contested statues, memorials and place names: Guidance for public bodies', University of Bristol, 2021 available at www.bridginghistories.com/heritage-resources

⁹ For more information, see the Project TRUTH report, by the Legacy Steering Group and Black South West Network: www.blacksouthwestnetwork.org/acc

BRISTOL VOICES

How do you feel about the statue being pulled down?

Page 79



“ A beautifully powerful act.

“ The law is the law and must be respected.

“ At first I saw it as destruction... but seeing it in the M Shed today it felt good.

“ As a Bristolian I feel proud of the fact that this happened in my city.

“ A brave thing to do.

“ There is a democratic process and they didn't exhaust it.

“ It shouldn't have been vandalised as it is a work of art.

“ It was hard for any black person to walk past every day.

“ It should have been removed earlier.

“ It was criminal damage by an unlawful mob.

“ Direct political action accomplished what bureaucracy couldn't.

Should the Colston statue be on display in a museum in Bristol?

“ It should be in a museum. Statues are celebratory, museums are educational.

“ I’d like to know more about how much of the city’s architecture came from money, directly or indirectly, due to the triangular trade.

“ Display it in a way that encourages reflection on Bristol’s past and the ripples of that past in the present, not reverence.

“ It’s not ‘rewriting history’ to remove a statue if it’s preserved in a museum in an appropriate context.

“ It should be cleaned up and restored to its rightful place on the plinth.

“ It should be reinstalled onto the plinth, then put to a vote.

“ I would like it to be displayed with the whole history surrounding it.

“ It should be part of a much bigger, dedicated museum / memorial and visitors center to educate the city about the transatlantic slave trade.

“ It shouldn’t be on display. We don’t need statues to be displayed of people who killed and murdered thousands. We do not need statues to remember their crimes.



What should be on the plinth?

“ Pulling down one statue won’t solve racial inequality, so what else can we do using this space to further that cause?

“ The plaque must be updated to reflect history.

“ I really don’t think anything should be put in place that commemorates what happened on 07/06/2020.

“ Remove plinth. People will not agree on what should go on it.

“ Let’s have a meeting place for poets, speakers, musicians, actors.

“ Love the idea of changing what is there! It is quite ‘Bristol’.

“ Empty is the only acceptable thing unless the statue is repaired and returned to its plinth, so that the world knows Bristol does not sanction riots and rioters!

“ An empty plinth leads to conversation.

“ A permanent replacement could be divisive.

“ As a work is replaced it could be displayed next to Colston in the museum, to keep the connection and conversations moving.

“ A real heroic Bristolian like Paul Stephenson.

“ The replacement should be non-political and conciliatory to everyone – after all Bristol is the home to people of all ages, beliefs and politics.



“ HOW ABOUT PUTTING UP...
“ BRUNEL

“ A CLIMATE CHANGE MEMORIAL
“ THOMAS CHATTERTON
“ MARY SEACOLE

“ A SLAVERY MEMORIAL
“ MARY CARPENTER

“ HEROES OF COVID 19
“ BANKSY

“ QUEEN ELIZABETH II
“ PRINCESS CAMPBELL

“ GROMIT
“ CARY GRANT

“ GEORGE MULLER
“ HANNAH MORE

CONCLUSION

Thinking differently is not a problem, but something to be celebrated.

Page 82

The survey has shown that there is much that we as a city agree on. Most of us think that the best place for the statue is in a museum in the city. Most of us think the plinth should remain, with a new plaque, and should be a space for ongoing conversation. There are also areas where our views differ. We should welcome this. Thinking differently is not a problem, but something to be celebrated. A core principle of democracy is not simply tolerating but valuing differences in opinion. The world – and our city – would be all the poorer without differences in the ways we think about the past, present and future.

Explore more ...

- ▶ The full report gives you a chance to look in more depth at how we did the survey, who responded, and at more of the voices and views of people who joined in.
www.bridginghistories.com/heritage-resources
- ▶ Let us know your thoughts and feedback.
activities@bridginghistories.com
- ▶ Explore and share your own history and heritage with Bridging Histories.
www.bridginghistories.com





You can get this document in large print, by email, in Braille, on CD, as a BSL DVD, in easy read with pictures or in community languages. You can also get a summary with pictures.

Please contact history@bristol.gov.uk

Bristol Museums & Art Gallery Condition Report

Object Bronze Statue of Colston

Dimensions (approx.)

980mm (Height)

2565mm (Length)

850mm (Width)

Digital Photos

B D A

Date of Report 1/10/20

Conservator A. Drewdun

Description

Large bronze statue of the Mr Colston, attached to a limestone base.

Condition

Overview:

The object has suffered damage from being torn down. The bronze has detached from the stone base, and the figure has suffered a large amount of graffiti. Overall, the bronze is missing the proper left lower side of the coat-tail, as well as the walking stick. The walking stick knob remains in the proper left hand. Significant surface abrasions and deep scratching has occurred in multiple places throughout the figure; most notably on the high points of the figure such as the arms, back, proper right lower part of the coat-tail, and side edges of the base. Silver, red and blue paint have been used / sprayed over the face, chest and arms, down the proper right of the coat, and on the proper leg. Due to nature of the acrylic paint used for the graffiti, and the many layers of wax, oil based varnish, along with the object being thrown into the harbour; the paint and protective layer has bubbled and flake off a fair amount overall. The protective layer of wax and varnish, and the paints continue to flake overall. Remnants of silt are exhibited throughout the exterior and interior. Due to the damage to the base of the bronze, the statue could not safely stand without significant intervention.

Condition starting at the head and working down to the base:

The top of the head shows a casting plug. The back of the head, as well as the front forehead / hair shows some surface abrasion and scratching along with silver and red graffiti paint. A small piece of cigarette paper (old) was also found stuffed up the proper right nostril. The loss of paint and protective layer is clearly observed throughout the bronze surface. The proper left arm was cast separate to the torso and has become a little misaligned from the fall. The arm remains secure but the join in the casting is very evident. Severe loss through abrasion is observed on the cuff / lower arm area. Further deep surface scratching noted on the proper right shoulder, elbow, with significant loss to the end of the coat cuff. Red and silver paint has been sprayed over the chest and arms. Silver paint has

also been sprayed in the arm cuffs and stomach area. Active spot corrosion is observed on the freshly abraded areas of the bronze, as well as in the interstices of the casting around the cuffs, folds of the coat around the stomach, the centre on the cane knob, the proper left hip and thigh, the underside of the coat-tail, and the underside of the base. Most corrosion is copper alloy; however iron pins / dowels have been used and so have corroded, on the knob and on the base.

The lower part of the coat has been cast in two sections. The proper right side has popped its rivets at the front and has become misaligned somewhat. This section is slightly wobbly. The proper left section is missing. The blue paint continues down the proper right side of the coat on the front. Significant loss is observed to the end and edges of the proper right front of the coat. There is a large vestige hole that is visible from the loss of the proper left lower part of the coat, in the hip / thigh area. Both legs display some blue paint, but most notably on the proper right leg. Both legs have flaking wax layers as well as paint. There is a tear in the bronze around the proper left heel of the shoe. The bronze base itself has torqued and deformed a little in this area from being wrenched off of the stone plinth that has several large bronze steaks / pins embedded, used to attach the statue to the base. The exterior side edges of the base have been hugely scratched and abraded, showing corrosion on the underside. Most of the corrosion overall is not significant enough to be a structural issue.

The stone base has staining over the writing from graffiti, pollution, and algae / plant material. There is significant loss to the stone on the high points of the carving such as the scrolls. The metal pins show some loss from the tearing down, with minor surface corrosion. The base also displays some minor cracking / fissures running through the carving. These look stable at present.



Face with silver and red paint, and silt.



Torso with silver and red paint, and silt.



Flaking paint.



Proper right cuff with deep abrasions and spot corrosion.



Proper left side showing loss of coat-tail and vestige hole.



Detaching proper right side of coat-tail.



Abrasion and surface damage on the end of the proper right coat-tail.



Proper left leg.



Tear in bronze under the left heel and bent base.



Stone base.



Stained stone with areas of surface abrasion.



Significant loss to the stone.



Damaged corner and edges of the stone with significant staining.

Internal - Antiquities Conservation

September 25, 2020

ECMAG.3640.1; Social History; statue Edward Colston statue



Bronze statue of Edward Colston. Cast in bronze. The clothes include a frock coat (early Georgian style/ possibly 1730s cut) over an unbuttoned waistcoat, shirt and breeches, a cravat around the neck, stockings gartered at the knee, and shoes with square buckles. Broad cuffs. One coat tail and the cane are missing. The ferrule of the cane remains in the palm of the hand

Materials

Dimensions

Approx: object lai			mm	
--------------------	--	--	----	--

Treatment

The graffiti was cleaned with cotton wool swabs and deionised water to remove silt . The rest of the bronze exterior was cleaned with cotton wool swabs, small brushes, with 70/30 IMS/deionised water, 0.5% Vulpex, and cleared with 80/30 deionised water and IMS. The interior of the bronze was cleaned using soft wire wool, stiff brushes , 50/50 deionised water and IMS, with 1% Vulpex, then cleared with 20/80 deionised water and IMS only. This removed more of the silt but not all as much of the interior was inaccessible through the cast hole in the left hip. Corrosion on the exterior was reduced using scalpels, abrasive medium and fine grit abrasive erasers, cleared / degreased with IMS, and dried with acetone. Microcrystalline wax was applied to these areas to provide an initial barrier. Cleaning process was interspersed with 10% Paraloid B67 in acetone used for the graffiti, and the flaking wax and resin layer - 5% Lascaux 495 50/50 deionised water / ethanol; both treatments activated using a heated spatula barriered with Melinex. The interior of the object was dried and warmed by two dehumidifiers and a small heater in-between consolidation. After 8 consolidate treatment campaigns consolidating the graffiti and 4 campaigns consolidating the old wax / resin layer, these areas were lightly buffed with dry cotton wool swabs to blend with the sheen of the rest of the bronze. There were several areas throughout that had lost the graffiti and the old protective wax/ resin layer, therefore after cleaning, these areas had a layer of 50/50 carnauba and microcrystalline applied and buffed with a soft cotton cloth to help protect it . Once dried, the rest of the bronze (not graffiti) was waxed overall with 50/50 bees wax/ microcrystalline wax for further surface protection. The interior was left unconsolidated and waxed to allow the metal to dry completely and adjust to the store environment, in order to prevent further exterior surface loss, particularly of the graffiti.

Date commenced: 12/Sep/2020

Total hours: 148

Date completed: 17/Oct/2020

Treated by:

Bristol Culture Collection Care and Preservation Policy & Strategy 2017-2022

Policy:

Bristol Culture has a primary commitment to the preservation of its collections. It seeks to achieve this through ensuring that:

- Preservation priorities are included in the aims and objectives of all forward planning.
- Those responsible for preservation priorities are included in any decision making team within the institution.
- There are regular reviews of the collections care strategy, which contribute to the revision of collections policies and programmes, ensuring a planned approach to improvements in overall collection care.
- The management team receives a quinquennial report on the general condition of the collection, which includes a description of areas of concern or special problems and an action plan containing recommendations on how the situation can be improved.
- Objects are cared for in accordance with recommendations in the relevant British and European Standards encompassing conservation and collections care as well as other relevant contemporary published research.

Bristol Culture is committed to assisting where possible with improving the standard of collections care and preservation throughout the South-West Region, in its position as the largest such service in the region.

Strategy:

The preventive conservator will liaise with the Operations Team on:

- Planned maintenance and other work on the structure of the museum buildings including cleaning regimes.
- Improvements to environmental control when the need is identified, through the Storage & Gallery KPI review document.
- The Senior Archivist takes on this role at BRO.

Standards of collections care are driven upwards through:

- Training of Collections and Archives staff in object handling, insect pest management and good housekeeping.

- Management support of Conservation staff CPD goals and enabling of training opportunities.
- Regular inspections of display and storage areas by responsible Collections & Archives staff. Any situations found requiring attention should be promptly reported to the appropriate officer.
- Regular communication and liaison between Collections and Conservation staff when planning any significant changes to storage and display arrangements.
- Best practice standards across all collections care areas are maintained: insect pest management; environmental monitoring and control; object handling, object labelling; housekeeping.

Standards of collections care will be maintained through ensuring:

- All artefacts must be labelled or marked according to the Bristol Culture policies.
- Good housekeeping practice and appropriate cleaning must be considered as the primary method of pest control.
 - Regular monitoring for pests by the preventive conservator and archivists with immediate reporting of pests by all staff must be observed.
 - Appropriate treatments must be ordered when necessary.
 - Artefacts on arrival at all sites must be inspected by a conservator and quarantined if necessary.
- Appropriate Collections or Archives staff must always supervise the handling, moving, operating and filming of artefacts and archives respectively.
- Records are kept of all environmental monitoring (RH, temperature, light and UV) and these are kept in a systematic way and retained for a minimum of five years.
- Environmental monitoring systems are regularly examined and improvements to control measures made where practicable, with the aim of achieving appropriate conditions.
- The conservation programme is regularly reviewed to set and monitor clear targets, and to check whether previous recommendations have been implemented.
- All conservation work is recorded according to professional practice standards on Bristol Culture's Collections Management System, EMu.



- A set of disaster guidelines is regularly updated and annual disaster procedure awareness training given to all staff.

Equality Impact Assessment [version 2.12]



Title: Assessment and determination of application for Listed Building Consent for “Proposal to move the statue of Edward Colston from Colston Avenue to M Shed.” (Application reference 23/04315/LA)	
<input type="checkbox"/> Policy <input type="checkbox"/> Strategy <input type="checkbox"/> Function <input type="checkbox"/> Service <input checked="" type="checkbox"/> Other Planning Decision	<input checked="" type="checkbox"/> New <input type="checkbox"/> Already exists / review <input type="checkbox"/> Changing
Directorate: Economy of Place	Lead Officer name: Jonathan Dymond
Service Area: Development Management	Lead Officer role: Case Officer

Step 1: What do we want to do?

The purpose of an Equality Impact Assessment is to assist decision makers in understanding the impact of proposals as part of their duties under the Equality Act 2010. Detailed guidance to support completion can be found here [Equality Impact Assessments \(EqIA\) \(sharepoint.com\)](https://sharepoint.com).

This assessment should be started at the beginning of the process by someone with a good knowledge of the proposal and service area, and sufficient influence over the proposal. It is good practice to take a team approach to completing the equality impact assessment. Please contact the Equality and Inclusion Team early for advice and feedback.

1.1 What are the aims and objectives/purpose of this proposal?

Briefly explain the purpose of the proposal and why it is needed. Describe who it is aimed at and the intended aims / outcomes. Where known also summarise the key actions you plan to undertake. Please use plain English, avoiding jargon and acronyms. Equality Impact Assessments are viewed by a wide range of people including decision-makers and the wider public.

This proposal relates to the assessment of an application for listed building consent for “Proposal to move the statue of Edward Colston from Colston Avenue to M Shed.” The reference for this application is 23/04315/LA, it was submitted in November 2023.

The proposal seeks to implement recommendations made by the We Are Bristol History Commission in their report “The Colston Statue: What Next?”, following the events of June 2020.

The application has been made by the City Council and is currently under assessment. It is expected that the application will be considered by a Development Control Committee, where a decision will be made on the application.

The decision on the application will be made under the Planning (Listed Buildings and Conservation Areas) Act 1990.

- The Public Sector Equality Duty is engaged, and it is therefore necessary to have due regard to the need to—
- (a) eliminate discrimination, harassment, victimisation and any other conduct that is prohibited by or under this Act [the Equality Act 2010];
 - (b) advance equality of opportunity between persons who share a relevant protected characteristic and persons who do not share it;
 - (c) foster good relations between persons who share a relevant protected characteristic and persons who do not share it.

It should be noted that an Equality Impact Assessment was undertaken in March 2022 by the Council in relation to the Cabinet approval to endorse and give authority to explore the steps required to implement the six recommendations within the We Are Bristol History Commission report “Colston Statue: What Next?”. To also

include acknowledgement of broader considerations, where they impact on Bristol City Council, and how these might be folded into the wider work done by the Council.

The applicant is Bristol City Council and they have stated in the application submission that “the statue of Edward Colston, a man with direct connections to the trans-Atlantic trafficking of enslaved people in the late 17th and early 18th century, was and remains an affront to many of Bristol’s citizens.” The application therefore does not propose the reinstatement of the statue as it is considered that “any reinstatement [understood to mean the return of the statue to the plinth] would cause additional upset and disgust and potentially lead to further public order and health and safety risks as well as damage community cohesion.”

1.2 Who will the proposal have the potential to affect?

<input checked="" type="checkbox"/> Bristol City Council workforce	<input checked="" type="checkbox"/> Service users	<input checked="" type="checkbox"/> The wider community
<input type="checkbox"/> Commissioned services	<input checked="" type="checkbox"/> City partners / Stakeholder organisations	
Additional comments:		

1.3 Will the proposal have an equality impact?

Could the proposal affect access levels of representation or participation in a service, or does it have the potential to change e.g. quality of life: health, education, or standard of living etc.?

If ‘No’ explain why you are sure there will be no equality impact, then skip steps 2-4 and request review by Equality and Inclusion Team.

If ‘Yes’ complete the rest of this assessment, or if you plan to complete the assessment at a later stage please state this clearly here and request review by the Equality and Inclusion Team.

<input checked="" type="checkbox"/> Yes	<input type="checkbox"/> No	[please select]
--	------------------------------------	-----------------

The proposal is considered to have an equality impact. This is considered to include impacts relating to quality of life, social cohesion and wellbeing.

Step 2: What information do we have?

2.1 What data or evidence is there which tells us who is, or could be affected?

Please use this section to demonstrate an understanding of who could be affected by the proposal. Include general population data where appropriate, and information about people who will be affected with particular reference to protected and other relevant characteristics: [How we measure equality and diversity \(bristol.gov.uk\)](https://www.bristol.gov.uk/how-we-measure-equality-and-diversity)

Use one row for each evidence source and say which characteristic(s) it relates to. You can include a mix of qualitative and quantitative data e.g. from national or local research, available data or previous consultations and engagement activities.

Outline whether there is any over or under representation of equality groups within relevant services - don't forget to benchmark to the local population where appropriate. Links to available data and reports are here [Data, statistics and intelligence \(sharepoint.com\)](#). See also: [Bristol Open Data \(Quality of Life, Census etc.\)](#); [Joint Strategic Needs Assessment \(JSNA\)](#); [Ward Statistical Profiles](#).

For workforce / management of change proposals you will need to look at the diversity of the affected teams using available evidence such as [HR Analytics: Power BI Reports \(sharepoint.com\)](#) which shows the diversity profile of council teams and service areas. Identify any over or under-representation compared with Bristol economically active citizens for different characteristics. Additional sources of useful workforce evidence include the [Employee Staff Survey Report](#) and [Stress Risk Assessment](#)

Data / Evidence Source [Include a reference where known]	Summary of what this tells us
Information included within the application for Listed Building Consent submitted by Bristol City Council (reference 23/04315/LA)	<p>The application includes a detailed supporting statement setting out the background to the proposal. It describes key events that took place prior to the submission of the application:</p> <p>“On 7th June 2020, the grade II listed bronze statue of Edward Colston was pulled down from its plinth on Colston Avenue during a Black Lives Matter demonstration. After being rolled through the City Centre, the statue was dumped into the Floating Harbour by a crowd of demonstrators.”</p>
We Are Bristol History Commission “The Colston Statue: What Next?” report – referred to in the application for Listed Building Consent submitted by Bristol City Council	<p>“In the summer of 2021, the ‘We are Bristol’ History Commission consulted with the public about the future of the Colston statue and the Colston plinth. People had a chance to see the statue and learn about its history in a temporary display at the M Shed museum, as well as view the display online. Alongside the display was a survey that invited people from Bristol and beyond to share their views on a number of questions”.</p> <p>According to the Listed Building Consent application, the key results from this consultation relevant to this application were that:</p> <ul style="list-style-type: none"> - 80% of respondees agreed that the statue should be displayed in a museum - 70% agreed that a new plaque should be added to the plinth - 14,000 people responded to the consultation from a good representative sample of the city population, over 50% of whom were from BS postcodes (History Commission short report pages 10-15)
Publicity relating to Listed Building Consent Application	<p>The Mayor of Bristol published a blog post on 9th November 2023 titled “The future of the Colston statue” (https://thebristolmayor.com/2023/11/09/the-future-of-the-colston-statue/). This stated the following relating to the application:</p> <p>“ It was through the We Are Bristol History Commission that we held a citywide conversation about the future of the statue and how we can build and present a better understanding of our history for this generation and the next. Nearly 14,000 people responded to the commission’s survey, with local residents and people from further afield taking part. The vast majority (80 per cent) of Bristol residents who responded agreed that the best place for the statue in future was in one of our museums.</p> <p>The History Commission made the same recommendation in their report. To help make this a reality an application to regularise the legal position</p>

Data / Evidence Source [Include a reference where known]	Summary of what this tells us
	<p>of the listed asset, away from its plinth, has recently been submitted which will go to a planning committee early in the new year. It was submitted following discussions with Historic England, the government advisory body responsible for designating listed buildings, as part of the pre-application process.</p> <p>Alongside this, a new M Shed exhibition is being developed and will open in March 2024, refreshing the theme of ‘protest’ in the People gallery. This will include Colston’s statue as part of an exhibit focusing on racial injustice.”</p> <p>Bristol Live also reported on the proposals in November 2023: https://www.bristolpost.co.uk/news/bristol-news/colston-statue-go-permanent-display-8895509</p>
Responses to the consultation on the application Listed Building Consent (reference 23/04315/LA) from consultees	Comments have been received from Historic England and the Council’s Conservation team. In summary, both responses do not raise objections to the application.
Responses to the consultation on the application Listed Building Consent (reference 23/04315/LA) from the public	<p>At the time of writing, four comments have been received, comprising two objections, one neutral comment and one comment in support.</p> <p>The consultation undertaken is a statutory consultation method that is prescribed by planning legislation. In this instance, this has included displaying a site notice at the site and publishing an advertisement in the local press. Where such consultation is undertaken in connection with an application, members of the public may view the application documents on the Council’s website and submit their comments.</p>
<p>Additional comments: These are the main sources of evidence that are considered to directly relate to the assessment and determination of the application for Listed Building Consent under the Planning (Listed Buildings and Conservation Areas) Act 1990.</p>	

1.1 2.2 Do you currently monitor relevant activity by the following protected characteristics?

<input type="checkbox"/> Age	<input type="checkbox"/> Disability	<input type="checkbox"/> Gender Reassignment
<input type="checkbox"/> Marriage and Civil Partnership	<input type="checkbox"/> Pregnancy/Maternity	<input type="checkbox"/> Race
<input type="checkbox"/> Religion or Belief	<input type="checkbox"/> Sex	<input type="checkbox"/> Sexual Orientation

2.3 Are there any gaps in the evidence base?

Where there are gaps in the evidence, or you don’t have enough information about some equality groups, include an equality action to find out in section 4.2 below. This doesn’t mean that you can’t complete the assessment without the information, but you need to follow up the action and if necessary, review the assessment later. If you are unable to fill in the gaps, then state this clearly with a justification.

For workforce related proposals all relevant characteristics may not be included in HR diversity reporting (e.g. pregnancy/maternity). For smaller teams diversity data may be redacted. A high proportion of not known/not disclosed may require an action to address under-reporting.

As this is a planning decision, protected characteristics are not monitored.

Regarding the consultation, further comments may be submitted prior to a decision being made on the application which will need to be taken into account and Public Forum Statement may also be made at the Development Control Committee meeting.

2.4 How have you involved communities and groups that could be affected?

You will nearly always need to involve and consult with internal and external stakeholders during your assessment. The extent of the engagement will depend on the nature of the proposal or change. This should usually include individuals and groups representing different relevant protected characteristics. Please include details of any completed engagement and consultation and how representative this had been of Bristol's diverse communities.

Include the main findings of any engagement and consultation in Section 2.1 above.

If you are managing a workforce change process or restructure please refer to [Managing a change process or restructure \(sharepoint.com\)](#) for advice on consulting with employees etc. Relevant stakeholders for engagement about workforce changes may include e.g. staff-led groups and trades unions as well as affected staff.

Under the Planning (Listed Buildings and Conservation Areas) Act 1990, there are specific requirements relating to publicity and consultation which must be followed in relation to any application for Listed Building Consent.

In this case, this has involved displaying a site notice at the site and the publishing of an advert in the local press. A site notice was displayed at the site on 22/11/2023 and a press advertisement was published on 22/11/2023. Consultation was also undertaken with Historic England, National Amenity Societies, the Council's Conservation team and the Conservation Advisory Panel. Comments have been received from consultees and the public, as mentioned above.

The Council is the applicant in this case and the application seeks to implement recommendations made by the We Are Bristol History Commission in their report "The Colston Statue: What Next?". The report includes the following summary:

"Nearly 14,000 people completed the survey (13,984). Of these, just over half were from Bristol (55 per cent). The Bristol participants were a cross-section of the city with people of every age, gender, ethnicity and deprivation level participating in large numbers. Every geographical area of the city took part. However, a few neighbourhoods had lower response rates, so we used outreach to encourage more people to join in from these neighbourhoods, and then gave equitable voice to each area of the city when analysing what people had written."

According to the Listed Building Consent application, the key results from this consultation relevant to this application were that:

- 80% of respondees agreed that the statue should be displayed in a museum
- 70% agreed that a new plaque should be added to the plinth
- 14,000 people responded to the consultation from a good representative sample of the city population, over 50% of whom were from BS postcodes (History Commission short report pages 10-15)

2.5 How will engagement with stakeholders continue?

Explain how you will continue to engage with stakeholders throughout the course of planning and delivery. Please describe where more engagement and consultation is required and set out how you intend to undertake it. Include any targeted work to seek the views of under-represented groups. If you do not intend to undertake it, please set out your justification. You can ask the Equality and Inclusion Team for help in targeting particular groups.

Insofar as the listed building consent application is concerned, conditions are likely to be recommended regarding the implementation of the works in order that the heritage benefits of the proposal can be secured – the enforcement of these conditions would be a matter of the local planning Authority.

If anyone had concerns regarding the planning decision or wished to challenge it, they could pursue this through the appropriate channels in the normal way.

Following the implementation of the proposal, however outside of the listed building consent application process, the M Shed also has a Collections statement (<https://www.bristolmuseums.org.uk/collections/action-on-decolonisation/collections-statement/>)

Step 3: Who might the proposal impact?

Analysis of impacts must be rigorous. Please demonstrate your analysis of any impacts of the proposal in this section, referring to evidence you have gathered above and the characteristics protected by the Equality Act 2010. Also include details of existing issues for particular groups that you are aware of and are seeking to address or mitigate through this proposal. See detailed guidance documents for advice on identifying potential impacts etc.

[Equality Impact Assessments \(EqIA\) \(sharepoint.com\)](#)

3.1 Does the proposal have any potentially adverse impacts on people based on their protected or other relevant characteristics?

Consider sub-categories and how people with combined characteristics (e.g. young women) might have particular needs or experience particular kinds of disadvantage.

Where mitigations indicate a follow-on action, include this in the 'Action Plan' Section 4.2 below.

GENERAL COMMENTS (highlight any potential issues that might impact all or many groups)

The applicant is Bristol City Council, and the application was submitted to the Local Planning Authority in November 2023.

The applicant is Bristol City Council and they have stated in the application submission that “the statue of Edward Colston, a man with direct connections to the trans-Atlantic trafficking of enslaved people in the late 17th and early 18th century, was and remains an affront to many of Bristol’s citizens.” The application therefore does not propose the reinstatement of the statue as it is considered that “any reinstatement [understood to mean the return of the statue to the plinth] would cause additional upset and disgust and potentially lead to further public order and health and safety risks as well as damage community cohesion.”

The proposal is therefore to move the statue to the M Shed. It is understood that a new M Shed exhibition is being developed and will open in March 2024, refreshing the theme of ‘protest’ in the People gallery. This will include Colston’s statue as part of an exhibit focusing on racial injustice. A new plaque will also be added to the plinth to provide additional explanation.

The statue forms part of the listed building and it’s display in a museum would help protect the physical object from further damage.

As noted above, the consultation on the listed building consent application has followed the normal methods required by legislation, however it should be noted that there has also been wider publicity associated with the submission of the application including a blog post by the Mayor of Bristol and coverage in the local press.

PROTECTED CHARACTERISTICS

Age: Young People	Does your analysis indicate a disproportionate impact? Yes <input type="checkbox"/> No <input checked="" type="checkbox"/>
Potential impacts:	
Mitigations:	
Age: Older People	Does your analysis indicate a disproportionate impact? Yes <input type="checkbox"/> No <input checked="" type="checkbox"/>
Potential impacts:	The report “The Colston Statue: What Next?” summary report, submitted with the Listed Building Consent application states the following with regard to how different groups feel about the statue coming down and attitudes by age:

	“Age appeared to make the biggest difference in how people felt about the statue being pulled down. Younger people reported more positive feelings about the statue coming down”
Mitigations:	
Disability	Does your analysis indicate a disproportionate impact? Yes <input type="checkbox"/> No <input checked="" type="checkbox"/>
Potential impacts:	
Mitigations:	
Sex	Does your analysis indicate a disproportionate impact? Yes <input type="checkbox"/> No <input checked="" type="checkbox"/>
Potential impacts:	The report “The Colston Statue: What Next?” summary report, submitted with the Listed Building Consent application states the following with regard to how different groups feel about the statue coming down and attitudes by age: “The survey showed some variation in attitudes by sex. 13 out of 20 female respondents felt positively, with similar feelings amongst people identifying as other, whereas 10 in 20 male respondents felt positively.”
Mitigations:	
Sexual orientation	Does your analysis indicate a disproportionate impact? Yes <input type="checkbox"/> No <input checked="" type="checkbox"/>
Potential impacts:	
Mitigations:	
Pregnancy / Maternity	Does your analysis indicate a disproportionate impact? Yes <input type="checkbox"/> No <input checked="" type="checkbox"/>
Potential impacts:	
Mitigations:	
Gender reassignment	Does your analysis indicate a disproportionate impact? Yes <input type="checkbox"/> No <input checked="" type="checkbox"/>
Potential impacts:	
Mitigations:	
Race	Does your analysis indicate a disproportionate impact? Yes <input type="checkbox"/> No <input checked="" type="checkbox"/>
Potential impacts:	“On 7 th June 2020, the grade II listed bronze statue of Edward Colston was pulled down from its plinth on Colston Avenue during a Black Lives Matter demonstration. After being rolled through the City Centre, the statue was dumped into the Floating Harbour by a crowd of demonstrators. The statue was recovered from the harbour and in the summer of 2021 went on display in the museum. While on display, Bristol City Council and the History Commission that had been established by the authority following the events in June, ran a public consultation process with visitors to the exhibition and online. This consultation asked what people thought should now happen to the statue and surviving plinth in the City Centre. The results of this consultation process informed a report by the commission that concluded with 6 recommendations for the future of the statue and plinth.” The report “The Colston Statue: What Next?” summary report, submitted with the Listed Building Consent application states the following with regard to how different groups feel about the statue coming down and attitudes by ethnicity: “Broadly speaking, people from different ethnic groups felt similarly about the statue coming down, and gave similar reasons for their feelings”
Mitigations:	The application proposes that the statue be moved to be displayed in the M Shed museum with accompanying contextual information combined with a proposed new plaque on the Colston Avenue plinth. Granting this Listed Building Consent application would regularise the position and provide certainty from a planning perspective regarding the proposed way forward.
Religion or Belief	Does your analysis indicate a disproportionate impact? Yes <input type="checkbox"/> No <input checked="" type="checkbox"/>
Potential impacts:	
Mitigations:	

Marriage & civil partnership	Does your analysis indicate a disproportionate impact? Yes <input type="checkbox"/> No <input checked="" type="checkbox"/>
Potential impacts:	
Mitigations:	
OTHER RELEVANT CHARACTERISTICS	
Socio-Economic (deprivation)	Does your analysis indicate a disproportionate impact? Yes <input type="checkbox"/> No <input checked="" type="checkbox"/>
Potential impacts:	
Mitigations:	
Carers	Does your analysis indicate a disproportionate impact? Yes <input type="checkbox"/> No <input checked="" type="checkbox"/>
Potential impacts:	
Mitigations:	
Other groups [Please add additional rows below to detail the impact for any other relevant groups as appropriate e.g. asylum seekers and refugees; care experienced; homelessness; armed forces personnel and veterans]	
Potential impacts:	
Mitigations:	

3.2 Does the proposal create any benefits for people based on their protected or other relevant characteristics?

Outline any potential benefits of the proposal and how they can be maximised. Identify how the proposal will support our [Public Sector Equality Duty](#) to:

- ✓ Eliminate unlawful discrimination for a protected group
- ✓ Advance equality of opportunity between people who share a protected characteristic and those who don't
- ✓ Foster good relations between people who share a protected characteristic and those who don't

Granting consent for the application would allow for the positive impacts associated with the proposal to be realised in terms of advancing equality of opportunity between people who share a protected characteristic and those who don't, and also through the fostering good relations between people who share a protected characteristic and those who don't.

In particular given that the statue relates to a man that the applicant submits has direct connections to the trans-Atlantic trafficking of enslaved people in the late 17th and early 18th century, was and remains an affront to many of Bristol's citizens.

It would also enable opportunity for a wide variety of people to learn about the history of Bristol through the display of the statue in the M Shed with associated accessible material.

Step 4: Impact

4.1 How has the equality impact assessment informed or changed the proposal?

What are the main conclusions of this assessment? Use this section to provide an overview of your findings. This summary can be included in decision pathway reports etc.

If you have identified any significant negative impacts which cannot be mitigated, provide a justification showing how the proposal is proportionate, necessary, and appropriate despite this.

Summary of significant negative impacts and how they can be mitigated or justified:

The presence of the statue in the M Shed may still cause offense to some. Some mitigation may be achieved through the new M Shed museum refreshing the theme of 'protest' in the People gallery. This will include Colston's statue as part of an exhibit focusing on racial injustice.

Summary of positive impacts / opportunities to promote the Public Sector Equality Duty:

There is considered to be overriding social benefit associated with the proposal.

4.2 Action Plan

Use this section to set out any actions you have identified to improve data, mitigate issues, or maximise opportunities etc. If an action is to meet the needs of a particular protected group please specify this.

Improvement / action required	Responsible Officer	Timescale
<p>The application has been made by the City Council and is currently under assessment. It is expected that the application will be considered by a Development Control Committee, where a decision will be made on the application.</p> <p>If the Committee resolves to grant Listed Building Consent, the applicant will have a set period of time to implement the consent. They will be required to comply with any relevant conditions.</p>	<p>The Local Planning Authority will be responsible for enforcement</p>	<p>Ongoing</p>

4.3 How will the impact of your proposal and actions be measured?

How will you know if you have been successful? Once the activity has been implemented this equality impact assessment should be periodically reviewed to make sure your changes have been effective your approach is still appropriate.

Insofar as the Listed Building Consent application is concerned, once consent is granted the applicant then has a period of time within which to implement the works. If any further applications were to be made, these would be assessed separately.

Step 5: Review

The Equality and Inclusion Team need at least five working days to comment and feedback on your EqIA. EqIAs should only be marked as reviewed when they provide sufficient information for decision-makers on the equalities impact of the proposal. Please seek feedback and review from the [Equality and Inclusion Team](#) before requesting sign off from your Director¹.

<p>Equality and Inclusion Team Review: <i>Reviewed by Equality and Inclusion Team</i></p>	<div style="background-color: black; width: 100px; height: 15px; margin-bottom: 5px;"></div> <div style="background-color: black; width: 150px; height: 40px;"></div>
<div style="background-color: black; width: 40px; height: 15px; display: inline-block;"></div>	<div style="background-color: black; width: 40px; height: 15px; display: inline-block;"></div> 12.2.2024

¹ Review by the Equality and Inclusion Team confirms there is sufficient analysis for decision makers to consider the likely equality impacts at this stage. This is not an endorsement or approval of the proposal.